

Initial Statement

SOUTHERN CALIFORNIA EDISON COMPANY BEFORE THE FEDERAL ENERGY REGULATORY COMMISSION

Southern California Edison Company

P-120

APPLICATION FOR LICENSE FOR MAJOR PROJECT—EXISTING DAM

1. Southern California Edison Company (SCE or Applicant) applies to the Federal Energy Regulatory Commission (Commission) for a new License for the Big Creek No. 3 Hydroelectric Power Project (Project), as described in the attached exhibits. The existing Project is designated as Project No. 120 in the records of the Commission, pursuant to a License issued by the Commission on September 7, 1977, and effective on September 1, 1977, for a period of 32 years from the expiration date of the prior long-term license, and terminating on February 28, 2009. This Application For New License for Major Project – Existing Dam is filed pursuant to 18 CFR §§ 4.51 and 16.9.

2. The location of the project is:

State: California

County: Fresno County and Madera County

Nearby Town: Auberry

River: San Joaquin

3. The exact name and business address of the applicant are as follows:

Southern California Edison Company

Attention: Nino J. Mascolo

Senior Attorney

P.O. Box 800

Rosemead, California 91770

(626) 302-4459

The exact name and business address of the person authorized to act as agent for the Applicant in this Application is

Russ W. Krieger
Vice President, Power Production
Southern California Edison Company
300 N. Lone Hill Avenue
San Dimas, CA 91773
(909) 394-8667

4. The Applicant is a domestic corporation. No municipal preference exists under section 7(a) of the Federal Power Act for this existing licensed Project.
- 5(i). The statutory or regulatory requirements in California, the state in which the Project is located, that affect the Project with respect to the bed and banks and to the appropriation, diversion, and use of water for power purposes and with respect to the right to engage in the business of developing, transmitting, and distributing power and in any other business necessary to accomplish the purposes of the license under the Federal Power Act are:

California Water Code Section 1200, et seq.; Title 23 California Code of Regulations Section 650, et seq., permits an application to be filed with the California Water Resources Control Board to obtain a permit or license to appropriate water, which is otherwise declared unappropriated, for beneficial uses including power uses.

California Water Code Section 13160; Title 23 California Code of Regulations Section 3855, regulates the federally required filing of applications for water quality certification with the California Water Resources Control Board.

Public Utilities Code, Section 201, et seq., regulates the right of the public utility to produce, generate, transmit, or furnish power to the public.

- 5(ii). The steps which the Applicant has taken or plans to take to comply with each of the laws cited above are:

Applicant has either obtained the necessary permits and licenses or otherwise acquired water rights by appropriation and/or prescription for use of Project water.

Licensee will file an application for a water quality certificate or waiver thereof with the California Water Resources Control Board in accordance with applicable state law and the Commission's regulations.

The California Public Utilities Commission has authorized SCE to produce, generate, transmit, or furnish power to the public.

6. The Applicant is the owner and existing licensee of the Project. The dam associated with the Project is not federally owned or operated.

Date:

2/21/07

By:



Russ W. Krieger
Vice President, Power Production

VERIFICATION

This Application For New License For Major Project – Existing Dam is executed in the

STATE OF CALIFORNIA
CITY OF SAN DIMAS
COUNTY OF LOS ANGELES

By: Russell W. Krieger
Vice President, Power Production
Southern California Edison Company
300 N. Lone Hill Avenue
San Dimas, California 91773

Russell W. Krieger, being first duly sworn, deposes and says: that he is a Vice President of Southern California Edison Company, the Licensee making the Application for New License for the Big Creek No. 3 Hydroelectric Power Project (FERC Project No. 120); that the contents of this Application are true to the best of his knowledge and belief. The undersigned Applicant has signed the Application this 21st day of February, 2007.

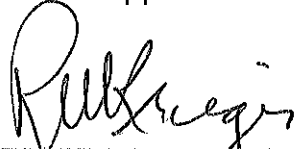

Russell W. Krieger
Vice President, Power Production

State of California
County of Los Angeles

On Feb. 21, 2007 before me, Lisa A. Smith, Notary Public personally appeared Russell W. Krieger personally known to me to be the person whose name is subscribed to the within instrument and acknowledged to me that he executed the same in his authorized capacity, and that by his signature on the instrument the person, or the entity upon behalf of which the person acted, executed the instrument.

WITNESS my hand and official seal.

Lisa A. Smith
Notary Public

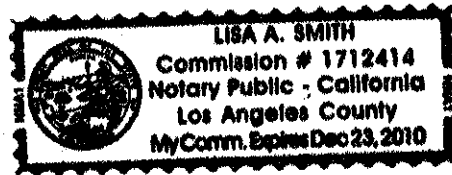

Section 4.32 General Information

This section of the Application for New License for the Project is intended to set forth the information required by 18 C.F.R §4.32, as follows:

- a) Each applicant must:
- (1) For a preliminary permit or license, identify every person, citizen, association of citizens, domestic corporation, municipality, or state that has or intends to obtain and will maintain any proprietary right necessary to construct, operate, or maintain the project;
 - (2) For a preliminary permit or a license, identify (providing names and mailing addresses):
 - (i) Every county in which any part of the project, and any Federal facilities that would be used by the project, would be located;
 - (ii) Every city, town, or similar local potential subdivision:
 - (A) In which any part of the project, and any Federal facilities that would be used by the project, would be located; or
 - (B) That has a population of 5,000 or more people and is located within 15 miles of the project dam;
 - (iii) Every irrigation district, drainage district, or similar special purpose political subdivision:
 - (A) In which any part of the project, and any Federal facilities that would be used by the project, would be located; or
 - (B) That owns, operates, maintains, or uses any project facilities or any Federal facilities that would be used by the project;
 - (iv) Every other political subdivision in the general area of the project that there is reason to believe would likely be interested in, or affected by, the application; and
 - (v) All Indian tribes that may be affected by the project.

(1) To the knowledge of Southern California Edison Company (SCE), no person, citizen, association of citizens, domestic corporation, municipality, or state, other than SCE has or intends to obtain any proprietary right necessary to construct, operate, or maintain the Project.

(2) (i) All Project boundaries and facilities are located in the County of Fresno and County of Madera, which has principal administrative offices located at:

Fresno County
Board of Supervisors
2281 Tulare Street, Room 301
Fresno, CA 93721

Madera County
Board of Supervisors
209 West Yosemite Avenue
Madera, CA 93637

(ii) None of the Project boundaries or facilities are located within any city, town, or other similar local political subdivision. There are no communities of 5,000 or more people located within 15 miles of the Project.

(iii) There are no irrigation districts, drainage districts, or other similar special purpose political subdivisions located within the Project area or which own, operate, or maintain any Project facilities. The Project does not use any federal facilities.

(iv) The following political subdivisions or nonpolitical organizations in the general area of the Project may be interested in the application:

Shaver Lake Chamber of Commerce
P.O. Box 58
Shaver Lake, CA 93664

North Fork Chamber of Commerce
P.O. Box 426
North Fork, CA 93643

North Fork Community Development Council
P.O. Box 1484
North Fork, CA 93643

Sierra Unified School District
31795 Lodge Road
Auberry, CA 93602

Big Creek Elementary School District
55190 Point Road
Big Creek, CA 93605

Pine Ridge Elementary School District
45828 Auberry Road
Auberry, CA 93602

Chawanakee School District
P.O. Box 400
North Fork, CA 93643

Toby Horst
Director, Sierra Resource Conservation District
36281 Lodge Road
Tollhouse, CA 93667

- (v) The Federally recognized Indian tribes and other Indian organizations that may be affected by, or interested in, the Project include:

Big Sandy Rancheria*
P.O. Box 337
Auberry, CA 93602

Cold Springs Rancheria*
P.O. Box 209
Tollhouse, CA 93667

North Fork Rancheria*
P.O. Box 929
North Fork, CA 93643

Dunlap Band of Mono Indians
P.O. Box 344
Dunlap, CA 93621

Picayune Rancheria*
46575 Road 417
Coarsegold, CA 93614

Table Mountain Rancheria*
23736 Sky Harbor Road
P.O. Box 410
Friant, CA 93626

Mono Nation
P.O. Box 800
North Fork, CA 93643

North Fork Mono Tribe
13396 Tollhouse Road
Clovis, CA 93611

Sierra Nevada Native American Coalition
P.O. Box 125
Dunlap, CA 93621

Bishop Tribal Council
50 Tu Su Lane
Bishop, CA 93514

Sierra Mono Museum
33103 Road 288
North Fork, CA 93643

Native Earth Foundation
34329 Shaver Springs Road
Auberry, CA 93602

Michahai Wuksachi
1174 Rockhaven Ct
Salinas, CA 93906

*Federally recognized tribal organization

SOUTHERN CALIFORNIA EDISON COMPANY
BEFORE THE
FEDERAL ENERGY REGULATORY COMMISSION

APPLICATION FOR NEW LICENSE

BIG CREEK No. 3
(FERC Project No. 120)

EXHIBIT A: DESCRIPTION OF PROJECT

CONTAINS PUBLIC INFORMATION

FEBRUARY 2007

Copyright 2007 by Southern California Edison Company. All rights reserved. No part of this publication may be reproduced, stored in a retrieval system, or transmitted, in any form or by any means, electronic, mechanical, photocopying, recording or otherwise, without the prior written permission of the Southern California Edison Company.

Exhibit A Description of Project

Exhibit A is a description of the project. This exhibit need not include information on project works maintained and operated by the U.S. Army Corps of Engineers, the Bureau of Reclamation, or any other department or agency of the United States, except for any project works that are proposed to be altered or modified. If the project includes more than one dam with associated facilities, each dam and the associated component parts must be described together as a discrete development. The description for each development must contain:

- (1) The physical composition, dimensions, and general configuration of any dams, spillways, penstocks, powerhouses, tailraces, or other structures, whether existing or proposed, to be included as part of the project;
- (2) The normal maximum surface area and normal maximum surface elevation (mean sea level), gross storage capacity and usable storage capacity of any impoundments to be included as part of the project;
- (3) The number, type, and rated capacity of any turbines or generators, whether existing or proposed, to be included as part of the project;
- (4) The number, length, voltage, and interconnections of any primary transmission lines, whether existing or proposed, to be included as part of the project [see 16 U.S.C. 796(11)];
- (5) The specifications of any additional mechanical, electrical, and transmission equipment appurtenant to the project; and
- (6) All lands of the United States that are enclosed within the project boundary described under each paragraph (h) of this section (Exhibit G), identified and tabulated by legal subdivisions of a public land survey of the affected area or, in the absence of a public land survey, by the best available legal description. The tabulation must show the total acreage of the lands of the United States within the project boundary.

(1) General Configuration

The Big Creek Powerhouse No. 3 Project is located on the south side of the San Joaquin River at the eastern upstream end of Redinger Lake Reservoir on the western slope of the Sierra Nevada range, approximately 35 miles northeast of the City of Fresno.

Project facilities, shown in Figure A-1, are located in Fresno County and Madera County, California and within the Sierra National Forest (SNF), administered by the

**Placeholder for Figure A-1
Project Facilities Big Creek 3**

Non-Internet Public Information

This Figure has been removed in accordance with the Commission regulations at 18 CFR Section 388.112.

This Figure is considered Non-Internet Public information and should not be posted on the Internet. This information is provided in Volume 3 of the Application for New License and is identified as “Non-Internet Public” information. This information may be accessed from the FERC’s Public Reference Room, but is not expected to be posted on the Commission’s electronic library, except as an indexed item.

United States Department of Agriculture-Forest Service (USDA-FS). The Project is operated as a reservoir-storage type plant with an installed operating capacity of 174.45 MW. Water for the Project is taken from the San Joaquin River just downstream of its confluence with Big Creek and conveyed to the Big Creek No. 3 Powerhouse through Tunnel No. 3. The energy generated by the Project is transmitted to the SCE transmission and distribution system and used for public utility purposes.

Big Creek Dam No. 6

The Big Creek Dam No. 6 is located across the San Joaquin River a short distance downstream from its confluence with Big Creek within Section 27, T8S, R24E, M.D.B. and M. It is a constant-radius concrete arch dam, 155 feet high. The top, at an elevation of 2,250 feet msl, is 495 feet long. The dam is eight feet thick at the top and 39 feet thick at the lowest point of the foundation.

The spillway, which is an overpour type, consists of six ungated spans, separated by piers, with a total length of 389 feet at an elevation of 2,230 feet msl. A walkway at 2,250 feet msl spans the ungated spillway for access to controls of four drainage gates, and to a 15-ton revolving crane for removal of floating debris.

Four, 66-inch diameter steel drain pipes pass through the base of the dam at 2,142 feet msl. Flow through these pipes is controlled by 100-inch slide gates at the upstream face and 72-inch slide gates at the downstream face of the dam. A 24-inch diameter cast iron drain pipe at the intake and an 8-inch diameter drain line also passes through the dam structure.

The dam's outlet works, located in an intake tower with full-height trash racks, a short distance upstream from the left abutment, form the entrance to Tunnel No. 3 which leads to Powerhouse No. 3. The tunnel has an invert elevation at 2,160 feet msl. Flow into Tunnel No. 3 is controlled by a 22-foot cylindrical gate at the bottom of the tower.

The reservoir created by Dam 6 has a gross storage capacity of 993 acre-feet and a surface area of 23.2 acres at the spill crest elevation of 2,230 feet msl.

Tunnel No. 3

The flowline consists of Tunnel No. 3, a 21-foot by 21-foot cross section, 28,191-foot long, unlined bore through granite which intersects the base of the surge tank and rock chamber at its downstream end. The surge tank is an underground chamber, 164 feet high, 60-inches in diameter at its base, necking to 25-inches in diameter at the mid section, and then expanding to approximately 75-inches in diameter at the top. An 18-foot

diameter, 310-foot long riveted steel pipe, downstream of the base of the surge tank divides unsymmetrically through two spherical manifolds into five penstocks after exiting the tunnel portal.

Adits

There are three adits connected to Tunnel No. 3. The adits were part of the construction of the tunnel and are occasionally used for inspection or maintenance of the tunnel.

Penstocks

The Project includes five penstocks. The penstocks associated with Powerhouse Unit Nos. 1, 2, and 3 are 1,386 feet, 1,365 feet, and 1,324 feet long, respectively. Each of the penstocks consist of a 90-inch diameter forge-welded steel pipe which reduces to 54 inches in diameter before connecting to the turbine. A 90-inch electric motor-operated butterfly valve is located at the upstream end of each penstock. This valve can be operated either locally or remotely from Big Creek Powerhouse No. 3. Each Penstock has a vent relief valve that is located just downstream of the butterfly valve.

The penstock associated with Powerhouse Unit No. 4 consists of a 1,322 feet long, 90-inch diameter butt-welded steel pipe which reduces to 54 inches in diameter before connecting to the turbine. A 90-inch electric-motor-operated butterfly valve is located at the upstream end of the penstock. This valve can be operated either locally or remotely from Big Creek Powerhouse No. 3. A vent relief valve is located just downstream of the butterfly valve.

The penstock associated with Powerhouse Unit No. 5 consists of a 1,346 feet long, 90-inch diameter butt-welded steel pipe which reduces to 63 inches in diameter before connecting to the turbine. A 90-inch electric-motor-operated butterfly valve is located at the upstream end of the penstock. This valve can be operated either locally or remotely from Big Creek Powerhouse No. 3. A vent relief valve is located just downstream of the butterfly valve.

Powerhouse

The powerhouse is a four-story concrete structure with a machine shop located adjacent to the south of the powerhouse. A small hazardous materials/waste storage area is located outside and east of the machine shop. Office space and the battery storage room are located on the mezzanine level, and the control room is located on the main generator floor level of the powerhouse.

Big Creek Dam No. 6 Controls

Controls include the necessary protection relays, instruments, switches, etc., for monitoring and controlling the turbine/generator system as well as all auxiliary equipment. A computer control system has been installed which permits automated control of the generating units. The units can be automatically monitored, started, and shut down with this system.

The computer system consists of a processing unit, a printer, keyboard, and a monitor. Provisions are provided to allow programming modification, troubleshooting, and diagnosing of system problems. To effect control of the entire Big Creek project, a Master Controller is housed in the control room. The Master Controller is utilized to monitor and control the operations of all the Big Creek powerhouses and provides the main Digital Dispatch Security Monitoring System (DDSMS) with continuous data.

Tailrace

The tailrace for the Big Creek No. 3 Powerhouse is located immediately adjacent to the San Joaquin River, behind a low wing-wall made of native rock. The wing-wall creates a back-water pond which protects the turbines from turbulence.

(2) Storage Capacity

The Powerhouse No. 3 forebay (created by Dam No. 6) has a surface area of 23.2 acres and a gross and usable storage capacity of 993 acre-feet at the spill crest elevation of 2,230 feet msl.

(3) Turbines and Generators

The powerhouse contains five main Francis-type vertical shaft hydraulic reaction turbines. The individual ratings for each turbine are as follows:

- The Unit 1 turbine is rated at 41,300 HP at a design head of 740 feet, operating at 514 RPM;
- The Unit 2 turbine is rated at 41,300 HP at a design head of 740 feet, operating at 514 RPM;
- The Unit 3 turbine is rated at 41,300 HP at a design head of 740 feet, operating at 514 RPM;
- The Unit 4 turbine is rated at 49,500 HP at a design head of 750 feet, operating at 450 RPM; and,

- The Unit 5 turbine is rated at 57,700 HP at a design head of 802 feet, operating at 450 RPM.

The Units 1, 2, and 3 generators are Y-connected, vertical shaft, partially enclosed Westinghouse units. These generators are rated at 34,000 kVA, unity power factor, three-phase, 13.8 kV, 60 Hz. The Unit 4 generator consists of a Y-connected, vertical shaft, Westinghouse unit that is rated at 40,000 kVA, 36,000 kW, three-phase, 12.5 kV, 60 Hz. The Unit 5 generator consists of a Y-connected, vertical shaft, totally enclosed Allis-Chalmers unit rated at 40,500 kVA, 36,450 kW, three-phase, 13.8 kV, 60 Hz.

In addition to the main generators, the powerhouse contains an emergency generator. The emergency generator, placed in operation in January 1994, is a horizontal shaft Onan unit. The generator is rated at 500 kW, 0.8 power factor, 240 volt, three-phase, 240 V, 60 Hz. The generator is connected to a 750 hp diesel engine.

(4) Primary Transmission Lines

There are no transmission lines associated with this Project.

(5) Mechanical, Electrical and Transmission Equipment

Oil Storage and Handling System

There are oil storage and transfer facilities for governor and bearing lubricating oil. Separate clean oil and used oil tanks are provided with an in-line centrifuge to purify lubricating and governor oil, as needed. The bearing oil systems for generator and turbine bearings consist of "AC" and "DC" motor-driven 5 gpm pumps.

Cooling Water System

Cooling water for generator, transformer, and bearing oil heat exchangers is taken from the tailrace by means of cooling water pumps and returned to the tailrace after once-through use as a coolant. The emergency cooling water system is supplied directly from penstocks in the event of a pump failure or other problems with the normal pump supply.

Valves

The Dam 6 low level outlet works are controlled by 100-inch slide gates at the upstream face and 72-inch slide gates at the downstream face of the dam. These valves can be operated locally by an electric motor or by handwheel control.

At the Dam 6 intake tower structure, flow into Tunnel No. 3 is controlled by a 22-foot cylindrical gate at the bottom of the tower. The gate can be operated by an electric motor or by a gasoline-powered motor driving a reduction gearbox that turns the gate. There is also a manual handwheel control that operates the gate.

The Units No. 1 through 5 penstocks each have a 90-inch electric-motor-operated butterfly valve that is located at the upstream end of each penstock. This valve can be operated either locally or remotely from Big Creek Powerhouse No. 3.

Units 1, 2, and 3 turbine shut-off valves are 54-inch plug-type valves which operate by 90 degree rotation from the “closed” to “full open” position. Valve operation can be accomplished either hydraulically or by a penstock water-operated cylinder and piston, or mechanically by a handwheel on a threaded shaft.

The Unit 4 turbine shut-off valve is a 72-inch butterfly valve, which operates in a horizontal shaft. This valve can be operated by an electric motor or by handwheel control.

The Unit 5 turbine shut-off valve is a 63-inch spherical valve equipped with retractable seals, an electric motor operator and a 10-inch bypass system. Normal operation of the valve is accomplished by an automatic sequencer. The valve can be manually controlled by pushbutton at the turbine shut-off valve control center mounted near the valve. It can also be operated by hand control at the turbine shut-off valve motor operator.

Governors

Normal turbine operating control is maintained by a Woodward mechanical hydraulic cabinet actuator for governing the hydraulic turbine systems for Units 1 and 2, consisting of two identical governor oil pumps, motors, pressure tanks, and sumps. Units 3 and 4 are equipped with a similar governor system. The operating pressure for these two governor systems ranges from 175 to 195 psig.

The Unit 5 turbine control is provided by a Woodward governor system which operates from 460 to 500 psig. These governor systems provide accurate speed control for synchronizing and for stable operation once the units are connected to the power system.

Gages

One powerhouse gage as follows:

USGS No.	SCE No.	Station Name
11241800	162	Big Creek PH No. 3

One stream gage as follows:

USGS No.	SCE No.	Station Name
11238600	124	San Joaquin River above Stevenson Creek at Dam 6

Generators

Units 1, 2 and 3 generators are Y-connected, vertical shaft, partially enclosed Westinghouse units. Cooling is provided by once-through air drawn from outside of the powerhouse after passing through a humidifier system. A main exciter, pilot exciter, and permanent magnetic generator (PMG) are directly connected to the top of each generator.

Unit 4 generator is a Y-connected, vertical shaft, Westinghouse unit cooled by a closed-circuit air system with heat exchangers. A main exciter, pilot exciter, and PMG are directly connected to the top of the generator.

Unit 5 generator is a Y-connected, vertical shaft, totally enclosed Allis-Chalmers unit cooled by heat exchangers. Excitation is provided by means of a solid-state exciter and automatic voltage regulation is provided by a solid-state voltage regulator.

The main generator installed ratings are as follows:

- Unit 1 - 34,000 kW, 1.0 power factor, 13.8 kV, 3-phase, 60 hz
- Unit 2 - 34,000 kW, 1.0 power factor, 13.8 kV, 3-phase, 60 hz
- Unit 3 - 34,000 kW, 1.0 power factor, 13.8 kV, 3-phase, 60 hz
- Unit 4 - 36,000 kW, 0.9 power factor, 12.5 kV, 3-phase, 60 hz
- Unit 5 - 36,450 kW, 0.9 power factor, 13.8 kV, 3-phase, 60 hz

Units 1, 2, 3, and 4 main generators are each protected by a single 15 kV, 2,000 amp, vacuum circuit breaker. Disconnect switches are provided at each breaker position for isolation. Unit 5 main generator is protected by a single 15 kV, 3,000 amp, 500 MVA air circuit breaker.

In addition to the main generators, the powerhouse contains an "Emergency" generator. The Emergency generator is a horizontal shaft, Onan unit. The generator is rated at 500 kW, 0.8 power factor, 240 volt, 3-phase, 60 Hz. The generator is driven by a 750 HP diesel engine.

Transformers

The unit main transformers are located on a concrete platform adjacent to the powerhouse and consist of three banks as follows:

- The No. 1 Transformer, which serves Units 1 and 2, consists of one three-phase, 77/109 MVA, 240-13.2 kV, OA/FA, 60 Hz transformer.
- The No. 2 Transformer, which serves Units 3 and 4, consists of one three-phase, 90/120 MVA, 240-13.2 kV, OA/FA, 60 Hz transformer.
- The No. 3 Transformer, which serves Unit 5, consists of one three-phase, 33/44 MVA, 230-13.8 kV, OA/FA, 60 Hz transformer.

Power Distribution Equipment

Powerhouse service light and power is provided from three sources: (1) the No. 1 Station Service Transformer, a 750 kVA, OA 13.2 kV-240 volt, 3-phase transformer bank which is fed from the No. 1 13.2 kV bank as the preferred source; (2) the No. 2 13.2 kV bank; or (3) the No. 2 station service transformer consisting of three 12 kV-240 volt, single-phase, 100 kVA units, each fed from the non-project 12 kV distribution substation.

The Emergency generator provides the back-up source for station light and power, and can provide "black-start" capability for the powerhouse.

Powerhouse control power is provided by a 60-cell, 415 ampere-hour, 120 volt, lead-acid storage battery bank charged with a solid state battery charger.

Heating, Ventilating, and Air Conditioning System

Control room heating and cooling for personnel and electronic equipment is provided by a central air conditioning and heating system.

Heating for the machine shop and office areas is provided by electric radiant heating. The powerhouse is ventilated by four air conditioners.

Compressed Air System

The powerhouse contains two motor-driven service air compressors complete with receiver and piping. The main station air compressor is a Dayton 125 CFM, and the auxiliary station air compressor is a Worthington 284 CFM machine. These compressors provide air for the generator braking systems and general station use. Three governor oil air compressors are also provided to supply air to the governor oil system cushion tanks.

Fire Protection System

Two portable 150 lb. Halon units are located on the generator floor for unit fire protection. Portable extinguishers, and fire hose reels (1-1/2 inch) and hydrants are provided in strategic locations within the powerhouse.

Unit Nos. 3, 4, and 5 contain their own dedicated generator fire suppression system.

Sanitary Disposal System

Sanitary facilities are provided in three locations within the powerhouse. One restroom facility is located in the control room area. A second facility is located on the generator floor elevation in the vicinity of the control room. The third facility is located in the machine shop area. The effluent is stored in a holding tank on the premises and transfer pumped to the camp facility septic and leach field.

Lighting

Normal powerhouse and machine shop lighting service is supplied from the station 240 volt bus. Lighting circuits are served by circuit breakers, disconnect switches, buses, and fuses. Emergency lighting from the powerhouse battery system is used to facilitate safe operation in the event of a lighting system failure or system outage.

Station Crane

The powerhouse is equipped with a 125-ton traveling crane with a 15-ton auxiliary hook which provides hoisting facilities for all major equipment. The machine shop is equipped with a 5-ton traveling crane with a 5-ton auxiliary hook. Dam No. 6 is equipped with a 15-ton stationary revolving crane for dam maintenance and trash removal.

Switching

The non-Project switchyard is located approximately 250 feet west of the powerhouse. Galvanized steel switchracks serve to support the 220 kV buses. The switchgear consists of sixteen, 3,000 amp, two 800 amp, and two 1,200 amp, remotely-operated, 3-pole, 220 kV, SF6 circuit breakers. Gang-operated disconnect switches, grounding switches, potential devices, and other related equipment are also located in the switchyard.

(6) Lands of the United States within Project Boundaries

Lands of the United States that are within the Project boundaries, including legal subdivisions and acreages, are listed in Table A-1.

Table A-1. Lands of the United States Within the Boundaries of the Big Creek No. 3 Project. (All the lands are under the jurisdiction of the U.S. Forest Service, Sierra National Forest).

Location	Area
Township 8 South, Range 24 East, MDM	
Section 22	
SE1/4 NW1/4	6.10
NE1/4 SW1/4	2.50
NW1/4 SE1/4	8.20
NE1/4 SE1/4	2.90
SE1/4 SE1/4	8.20
NW1/4 NE1/4	4.26
SW1/4 NE1/4	1.90
Section 27	
NE1/4 NE1/4	13.50
SE1/4 NE1/4	10.20
NE1/4 SE1/4	1.40
NW1/4 SE1/4	5.50
SW1/4 SE1/4	3.40
SE1/4 SW1/4	3.60
Section 33	
NE1/4 SE1/4	3.80
NW1/4 SE1/4	1.10
SW1/4 SE1/4	2.20
SE1/4 SE1/4	2.40
SE1/4 SW1/4	4.10
SW1/4 SW1/4	0.20
Section 34	
NE1/4 NW1/4	7.30
SE1/4 NW1/4	4.20
SW1/4 NW1/4	4.10
NW1/4 SW1/4	6.80
SW1/4 SW1/4	1.40
Township 9 South, Range 24 East, MDM	
Section 3	
Gov. Lot 3	0.50
Gov. Lot 4	1.30
SW1/4 NW1/4	3.40
NW1/4 SW1/4	2.20
Section 4	
NW1/4 NE1/4	1.60
SW1/4 NE1/4	3.40
SE1/4 NW1/4	0.10
NW1/4 SE1/4	3.10
SW1/4 SE1/4	4.90
SE1/4 SE1/4	4.30
NE1/4 SE1/4	1.30

Table A-1. Lands of the United States Within the Boundaries of the Big Creek No. 3 Project (continued). (All the lands are under the jurisdiction of the U.S. Forest Service, Sierra National Forest.)

<u>Location</u>	<u>Area</u>
Township 9 South, Range 24 East, MDM (continued)	
Section 8	
SE1/4 NE1/4	3.40
NE1/4 SE1/4	3.40
SE1/4 SE1/4	5.86
Section 9	
NE1/4 NE1/4	1.30
NW1/4 NE1/4	6.80
SW1/4 NE1/4	1.40
NE1/4 NW1/4	1.10
SE1/4 NW1/4	5.90
SW1/4 NW1/4	3.20
NE1/4 SW1/4	1.90
NW1/4 SW1/4	2.10
SW1/4 SW1/4	2.40
Section 17	
NE1/4 NE1/4	4.88
NW1/4 NE1/4	5.00
NE1/4 NW1/4	0.90
SW1/4 NE1/4	3.80
SE1/4 NW1/4	8.70
NE1/4 SW1/4	6.80
SW1/4 NW1/4	29.00
NW1/4 SW1/4	16.40
SE1/4 SW1/4	0.50
NW1/4 NW1/4	0.01
Section 18	
NE1/4 NE1/4	1.66
SE1/4 NE1/4	30.65
SW1/4 NE1/4	22.30
SE1/4 NW1/4	6.60
NE1/4 SW1/4	27.90
SE1/4 SW1/4	4.10
NW1/4 SE1/4	15.80
NE1/4 SE1/4	18.04
<u>TOTAL FEDERAL LAND ACREAGE</u>	<u>377.16</u>

SOUTHERN CALIFORNIA EDISON COMPANY
BEFORE THE
FEDERAL ENERGY REGULATORY COMMISSION

APPLICATION FOR NEW LICENSE

BIG CREEK No. 3
(FERC Project No. 120)

EXHIBIT B: STATEMENT OF OPERATION
AND RESOURCE UTILIZATION

CONTAINS PUBLIC INFORMATION

FEBRUARY 2007

Copyright 2007 by Southern California Edison Company. All rights reserved. No part of this publication may be reproduced, stored in a retrieval system, or transmitted, in any form or by any means, electronic, mechanical, photocopying, recording or otherwise, without the prior written permission of the Southern California Edison Company.

Exhibit B Statement of Operation and Resource Utilization

Exhibit B is a statement of project operation and resource utilization. If the project includes more than one dam with associated facilities, the information must be provided separately for each such discrete development. The exhibit must contain:

- (1) A statement whether operation of the powerplant will be manual or automatic, an estimate of the annual plant factor, and a statement of how the project will be operated during adverse, mean, and high water years;
- (2) An estimate of the dependable capacity and average annual energy production in kilowatt-hours (or a mechanical equivalent), supported by the following data:
 - (i) The minimum, mean, and maximum recorded flows in cubic feet per second of the stream or other body of water at the powerplant intake or point of diversion, with a specification of any adjustments made for evaporation, leakage, minimum flow releases (including duration of releases), or other reductions in available flow; monthly flow duration curves indicating the period of record and the gauging stations used in deriving the curves; and a specification of the period of critical streamflow used to determine the dependable capacity;
 - (ii) An area-capacity curve showing the gross storage capacity and usable storage capacity of the impoundment, with a rule curve showing the proposed operation of the impoundment and how the usable storage capacity is to be utilized;
 - (iii) The estimated hydraulic capacity of the powerplant (minimum and maximum flow through the powerplant) in cubic feet per second;
 - (iv) A tailwater rating curve; and
 - (v) A curve showing powerplant capability versus head and specifying maximum, normal, and minimum heads;
- (3) A statement, with load curves and tabular data, if necessary, of the manner in which the power generated at the project is to be utilized, including the amount of power to be used on-site, if any, the amount of power to be sold, and the identity of any proposed purchasers; and

- (4) A statement of the applicant's plans, if any, for future development of the project or of any other existing or proposed water power project on the stream or other body of water, indicating the approximate location and estimated installed capacity of the proposed developments.

(1) Type of Operation

The Big Creek No. 3 Project Powerhouse, located on the San Joaquin River, is operated locally from the Big Creek No. 3 Powerhouse control room or remotely from the Big Creek dispatch center which serves as the main control center for the entire SCE Big Creek Hydroelectric System.

Project Operations

Operation of SCE's seven FERC-Licensed Projects in the Big Creek System (BCS) is managed from a watershed-wide perspective and on an individual project-by-project basis. The Big Creek Hydroelectric System consists of six major reservoirs (Thomas A. Edison, Florence, Huntington, Redinger, Shaver, and Mammoth Pool) and nine powerhouses (Portal; Eastwood; Mammoth Pool; and Big Creek Powerhouse Nos. 1, 2, 2A, 3, 4, and 8). Figure B-1 presents a schematic diagram of the seven FERC-Licensed Projects and associated reservoirs, water conveyance tunnels and powerhouses in the BCS. The operation of the BCS and the individual Projects is dependent on natural run-off during periods of snowmelt and wet weather and the operation of other components in the system, the amount of generation required for SCE's customers, and the dispatching of energy in accordance with the California Independent System Operator requirements.

SCE operates the four Big Creek ALP projects within the BCS in accordance with the FERC-license conditions, which includes minimum instream flow (MIF) release requirements that are made by SCE from diversions and impoundments.

The management of water through the BCS and specifically the four Big Creek ALP Projects routes water between Projects in a manner that best meets the operational constraints that are imposed either by contractual operating agreements (i.e., licenses, permits, etc.) or by physical limitations of the Project infrastructure. The BCS is subject to several operating constraints including the following: (1) available water supply; (2) electrical system requirements; (3) both planned and unplanned maintenance outages; (4) storage limits (including both recreation minimums and year-end carryover maximums); (5) both minimum and maximum release limits (from storage); (6) various provisions contained

in water rights agreements; and (7) California Independent System Operator requirements.

Water Rights and Contractual Obligations

Each of SCE's Big Creek Hydroelectric Projects either has separate water rights or shares one or more water rights with other projects for the diversion, use, and storage of water. The majority of the water rights are for non-consumptive uses associated with the generation of power. A few locations, such as the SCE's administrative offices and company housing near Big Creek No. 1 Powerhouse have minor consumptive water rights. SCE does not hold water rights for the consumptive use of water by any party other than SCE, nor does SCE sell any water rights associated with the hydropower projects to other parties.

SCE's water rights were obtained pursuant to state law and a majority of the water rights are documented by licenses and permits issued to SCE, or its predecessors, by the State Water Resources Control Board (State Water Board). Additional water rights were obtained through appropriation of water prior to the implementation of the Water Commission Act of 1914, and by prescriptive use against other parties. SCE also holds other water rights as a riparian land owner, which authorizes SCE to divert and use water on land owned by SCE.

The water rights agreements contain stipulations that stem from the senior status of certain downstream water rights holders. Generally, any water right holder with senior rights began diverting water for consumptive purposes prior to SCE or its predecessors. To protect the rights of the downstream water rights holders, SCE entered into agreements that restrict the use of water within the BCS to non-consumptive purposes, i.e., hydroelectric generation. Certain agreements limit the length of time and amount of water that SCE can store in its Project reservoirs. In a few instances, SCE's non-consumptive water use is a senior water right, and other water users hold junior water rights.

SCE operates its reservoirs consistent with the Mammoth Pool Operating Agreement (MPOA), which specifies cumulative reservoir storage constraints based on the computed natural run-off for the water year at Friant Dam. The MPOA between SCE and the U.S. Bureau of Reclamation (Bureau) specifies water storage and release requirements for the BCS reservoirs, which are upstream of Friant Dam (Millerton Reservoir) and the associated Central Valley Project water distribution system operated by the Bureau on behalf of the downstream irrigators. Millerton Reservoir is a major irrigation storage facility serving the central San Joaquin Valley agricultural community. Meetings between SCE, the Bureau, and the downstream irrigators are held following the March 1 runoff forecast each year, and periodically as needed, to coordinate and

optimize hydropower production consistent with irrigation needs of the downstream agricultural users holding senior water rights and emergency flood control operations of Millerton Reservoir. The MPOA includes constraints on the annual and seasonal timing and volume of releases from SCE's reservoirs, maximum year-end storage allowed, and minimum seasonal flow from Dam No. 7 (release and diversion).

BCS Water Management

A key component of the annual water management plan for the BCS is the development of an annual run-off forecast. The annual run-off forecast is developed based on snow pack and precipitation data collected in the vicinity of the Project. This information is used along with assumptions about future median precipitation and air temperatures to produce a run-off forecast through the end of the water year (September 30). The forecast includes an estimate of both the timing and the quantity of water that will enter Project reservoirs during that run-off season. Snow pack and precipitation data are shared with the California Department of Water Resources (DWR) and the Bureau, who use it to develop individual forecasts of run-off volumes and declare water year types (critical, dry, below normal, above normal, or wet). The run-off forecast is a valuable tool for planning and ensuring compliance with the constraints of the MPOA (described above) and for planning purposes. A majority of the MPOA and other constraints are based on actual run-off volumes. The forecast also is used for directing future operational plans for: 1) instream flow release requirements; 2) reservoir recreational storage requirements; and 3) hydroelectric generation operations for the entire BCS.

The operation of the BCS is similar in all water year types in that water diverted from Project reservoirs and diversions is utilized to generate power. There are subtle differences, however, in the way that the Project is operated during different water year types and during different conditions of state energy requirements.

Some of the BCS reservoirs generally spill in wet and above normal water years and are filled to maximum capacity when spill ceases. When the BCS reservoirs stop spilling, SCE is able to manage the system with available inflows and begin managing the water to meet electric supply requirements by providing both base load and peak cycling energy. In the upper basin area, water from the upper South Fork San Joaquin River drainage is stored in Florence Lake and water from Mono Creek drainage is stored in Lake Thomas A. Edison. Water is diverted from these two lakes and various other small backcountry diversions into Huntington Lake via the Ward Tunnel and the Mono-Bear Siphon. The volumes of water that can pass through Ward Tunnel and the siphon are limited by the physical size and layout of these conduits. Water deliveries to Huntington Lake are prioritized as follows: first

priority is given to water from Florence Lake; second priority is given to water from Bear Diversion and Lake Thomas A. Edison; and third priority is given to water diverted from the small diversions at Camp 61 Creek, Camp 62 Creek, Chinquapin Creek and Bolsillo Creek. The water delivered to Huntington Lake may also pass through Portal Powerhouse at the exit of the Ward Tunnel depending upon the amount of water being transported.

BCS Power Generation

The BCS has three interlinked water chains or pathways through which water may be transported and used to produce power. The three water chains are:

- Huntington Water Chain: This chain consists of Portal Powerhouse, Powerhouse No. 1, Powerhouse No. 2, Powerhouse No. 8, Powerhouse No.3, and Powerhouse No. 4.
- Shaver Water Chain: This chain consists of Portal Powerhouse, Eastwood Power Station, Powerhouse No. 2A, Powerhouse No. 8, Powerhouse No. 3, and Powerhouse No. 4.
- Mammoth Water Chain: This chain consists of Mammoth Pool Powerhouse, Powerhouse No. 3, and Powerhouse No. 4.

After passing through or bypassing the Portal Powerhouse, water entering Huntington Lake is directed to either the Huntington Chain, or the Shaver Chain. If the generation from the powerhouses of either chain is increased or decreased proportionally, the changes in load will have no effect on the MIF, or total levels of the storage reservoirs and forebays within the BCS. Changes in total loading conditions of the two chains can, however, affect Florence Lake and Lake Thomas A. Edison and can affect the amount of water leaving the project at Powerhouse No. 4. If generation from the powerhouses of either chain is changed disproportionately, the levels of Huntington Lake, Shaver Lake, and Redinger Lake can be increased or decreased.

Water from Big Creek Powerhouse Nos. 1 and 2 in the Huntington Chain joins water from the Shaver Chain, which has already passed through Eastwood Power Station and Big Creek Powerhouse No. 2A, at the Big Creek Powerhouse No. 2 and 2A Tailrace (Dam 5). Water from these two chains is then diverted through Big Creek Powerhouse No. 8, after which it joins the waters of the San Joaquin River coming from the Mammoth Chain at the Big Creek No. 8 Tailrace (Dam 6 Impoundment). Water from all three chains then continues through Big Creek Powerhouse Nos. 3 and 4.

Waters from the Middle Fork and North Fork San Joaquin River (SJR) drainages, and the South Fork SJR flows not diverted at Florence Lake, Lake Thomas A. Edison, Bear Creek Forebay, and the small backcountry diversions, are collected in Mammoth Pool Reservoir and become part of the Mammoth Chain. Mammoth Pool Powerhouse is usually run at maximum during the high flow or run-off period to prevent or delay spill at Mammoth Pool Reservoir.

For the most part, Portal Powerhouse, Eastwood Power Station, and Big Creek No. 4 Powerhouse operate independently of the other powerhouses in the BCS. Portal Powerhouse opportunistically uses water passing through the Ward Tunnel for power generation, but only operates efficiently at moderate flows through Ward Tunnel. Ward Tunnel flows outside the efficient flow range of Portal Powerhouse bypass Portal Powerhouse through the Howell Bunger (HB) valve into Huntington Lake. Eastwood Power Station generation normally occurs during the peak demand period of the day, unless water is being moved continuously from Huntington Lake to Shaver Lake to avoid spill at Huntington Lake or to increase storage at Shaver Lake for use during peak periods. Maintaining storage (water surface levels) to maintain recreational needs at Huntington Lake and above pump-back minimum water surface level in Shaver Lake are important considerations when planning operations at Eastwood Power Station. Big Creek Powerhouse No. 4 is the last power generation opportunity in the Big Creek System and therefore adjustments in the operation of the Powerhouse No. 4 will not affect other upstream powerhouses in the BCS.

Generally, the three water chains of the BCS are operated around the clock in the spring run-off period, except in dry water years. Operational flexibility is limited during normal run-off because the amount of water run-off available exceeds the combined generation and storage capacity of the project, resulting in water flowing over spillways or "spill".

After the end of the spill period, daily unit plant load schedules are established to maximize hydro resources during system peak load periods. When spring run-off is finished, if a powerhouse does not need to operate for water management, it is run preferentially during on-peak hours. Due to the nature of the energy market and SCE's resources, it is generally beneficial for the Big Creek Projects to provide power during on-peak hours, once the spring runoff has finished. Since the BCS powerhouses discharge to reservoirs or forebays, the peaking operations generally do not cause varying flows in bypass reaches. Energy load changes on these power generation chains will not affect the water surface elevation (WSE) or instream flows, as long as adjustments are made to match reservoir inflows and outflows. A proprietary computer model used for predicting inflow is also used to plan monthly flow of water through the Project to meet the operating constraints on the system while maximizing generation during the peak

load periods. In addition, computer programming of load schedules to use the most efficient units first, further enhances these operating activities and improves system integrity and efficiency. These activities can ensure the efficient use and availability of hydroelectric generation resources from these reservoir storage plants.

Market constraints and pricing, as well as transmission constraints and weather, will affect generation and operations at the Big Creek Projects. Often during the spring run-off season there is a financial disadvantage for SCE to generate energy even though to avoid generation would cause spill to occur. A simplified description of the California energy market describes the Independent System Operator (ISO) as having the role of balancing energy demand and supply in the state. The ISO takes the energy demand forecast, the transmission system constraints, and the energy that is bid into the day-ahead market to determine the acceptable energy supply. The ISO then adjusts the supply load on a real-time basis to account for changing conditions. If the ISO believes that there is a surplus of energy available beyond that necessary to supply the grid, prices in the California energy market for additional energy could be negative. This situation would require SCE to pay for contributing additional energy.

Water Management of Big Creek No. 3 Project (FERC Project No. 120)

The flow of water through the Big Creek No. 3 Project is dependent on natural run-off during periods of snowmelt and wet weather, and the operation of other components of the Big Creek Hydroelectric System that are located at higher elevations within the drainage. Big Creek Powerhouse No. 3 is one of the last generating opportunities in each of the water chains listed above, as water is moved from Florence Lake, Edison Lake, Huntington Lake, Shaver Lake, Mammoth Pool, and various tributaries through the water chains. The Project receives water from the Dam 6 impoundment and discharges into Redinger Lake. The Powerhouse No. 3 Project operates in conjunction with the rest of the BCS in a stair step sequence of water chains.

The operation of the Powerhouse No. 3 Project is similar in all water year types in that water diverted into the Project from remote impoundments and diversions is utilized to generate power when the water is available. In wet years, the Project is generally run at full capacity beginning in May until the end of peak run-off, which typically occurs in late July. Once SCE gains control of inflows, powerhouse operation is managed to meet grid requirements by providing both base load and/or peak cycling energy. Project generation is greater during wet water years and the Dam 6 outlet works and spillway may be used to also bypass water around the powerhouse, if necessary.

In above normal water years, the Project is generally run at full capacity beginning in May until the end of peak run-off, which typically occurs in July. Some of the BCS reservoirs generally spill in above normal water years and are filled to maximum capacity until spill ceases. At that time, SCE gains control of inflows and begins managing powerhouse operations to meet grid requirements by providing both base load and/or peak cycling energy. The water flow through the Big Creek No. 3 Powerhouse is generally matched to the flow entering Dam 6.

During dry water years, the Project may run at full capacity for a short duration in May and June. In some dry water years, the Project does not run at full capacity in order to fill the reservoirs to maximum capacity. Project generation is lower in dry water years and very little water, other than dam seepage and required MIF releases, bypasses the powerhouses.

Under the Proposed Action, water management would remain generally the same as existing operations.

(2) Capacity and Production

The installed Exhibit M capacity of the Project is rated at 174.45 MW. The Project has been tested to produce 183.26 MW. However, due to generator shaft and penstock vibration on Unit 3 and generator shaft vibration on Unit 4, the plant is restricted to producing 181.9 MW which is listed as the dependable capacity for the Project. The average annual capacity factor for the Project between 1991 and 2005 was 53.9%. The annual Project generation output between 1991 and 2005 is provided in Table B-1.

Table B-1 Average Project Generation Output Between 1991-2005.

Year	Production in MWH (Transmitted)
1991	580,415
1992	507,570
1993	1,094,090
1994	567,399
1995	1,195,652
1996	1,050,192
1997	898,483
1998	1,094,868
1999	839,673
2000	837,543
2001	570,805
2002	717,201
2003	752,412
2004	708,633
2005	946,278
15-year average =	824,081

- (i) Daily average available flows — Powerhouse No. 3 utilizes water stored in the impoundment formed by Dam 6 which includes water from Lake Edison (FERC Project No. 2086), Florence Lake (FERC Project No. 67), Shaver Lake (FERC Project No. 67), Huntington Lake (FERC Project No. 2175), and the Mammoth Pool Reservoir (FERC Project No. 2085). The following statistics represent the total available flow at Dam 6 and were derived by subtracting the minimum instream flow required downstream of Dam 6 (3 cfs) from the sum of the mean daily flows in the San Joaquin River downstream of Dam 6 (USGS Gage No. 11238600) and the throughput at Powerhouse No. 3 (USGS Gage No. 11241800). The period of record used for this analysis was October 1, 1982 to September 30, 1983 and October 1, 1984 to September 30, 2002.

Minimum	0 cfs
Median	1,551 cfs
Mean	2,087 cfs
Maximum	32,188 cfs

Figure B-2 presents the monthly flow duration curves for the same period of record between October 1, 1982 and September 30, 1983 and October 1, 1984 and September 30, 2002.

- (ii) Figure B-3 presents the area-capacity curves for the Dam 6 impoundment.
- (iii) The total estimated hydraulic capacity for the Project is 3,291 cfs and the total estimated minimum hydraulic capacity is 189 cfs. Big Creek No. 3 Unit 1 operates between 55 cfs and 637 cfs, Unit 2 operates between 44 cfs and 675 cfs, Unit 3 operates between 23 cfs and 628 cfs, Unit 4 operates between 16 cfs and 702 cfs, and Unit 5 operates between 51 cfs and 649 cfs.
- (iv) Tailwater rating curve – No gaging occurs in the tailrace of the Big Creek No. 3 Powerhouse since there is no effect from backwatering on the Project operations. The tailrace of the Powerhouse discharges into Redinger Lake. Because there is no gaging in this area, there are no rating curves for the tailrace.
- (v) Figure B-4 presents the powerhouse capability versus head curve for Big Creek Powerhouse No. 3.

FIGURES

ELEVATION – FEET

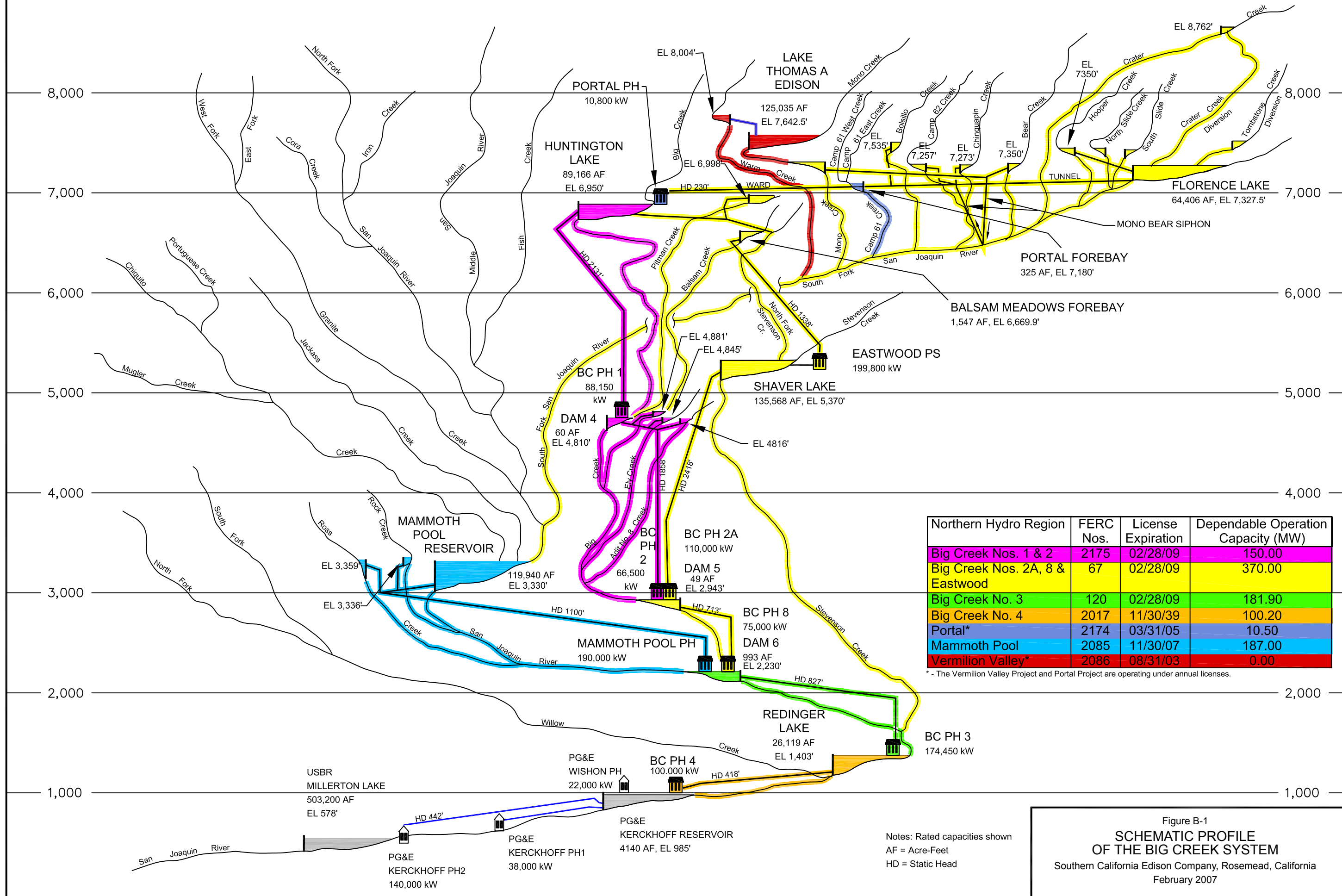

Northern Hydro Region	FERC Nos.	License Expiration	Dependable Operation Capacity (MW)
Big Creek Nos. 1 & 2	2175	02/28/09	150.00
Big Creek Nos. 2A, 8 & Eastwood	67	02/28/09	370.00
Big Creek No. 3	120	02/28/09	181.90
Big Creek No. 4	2017	11/30/39	100.20
Portal*	2174	03/31/05	10.50
Mammoth Pool	2085	11/30/07	187.00
Vermilion Valley*	2086	08/31/03	0.00

* - The Vermilion Valley Project and Portal Project are operating under annual licenses.

Notes: Rated capacities shown
 AF = Acre-Feet
 HD = Static Head

Figure B-1
SCHEMATIC PROFILE OF THE BIG CREEK SYSTEM
 Southern California Edison Company, Rosemead, California
 February 2007

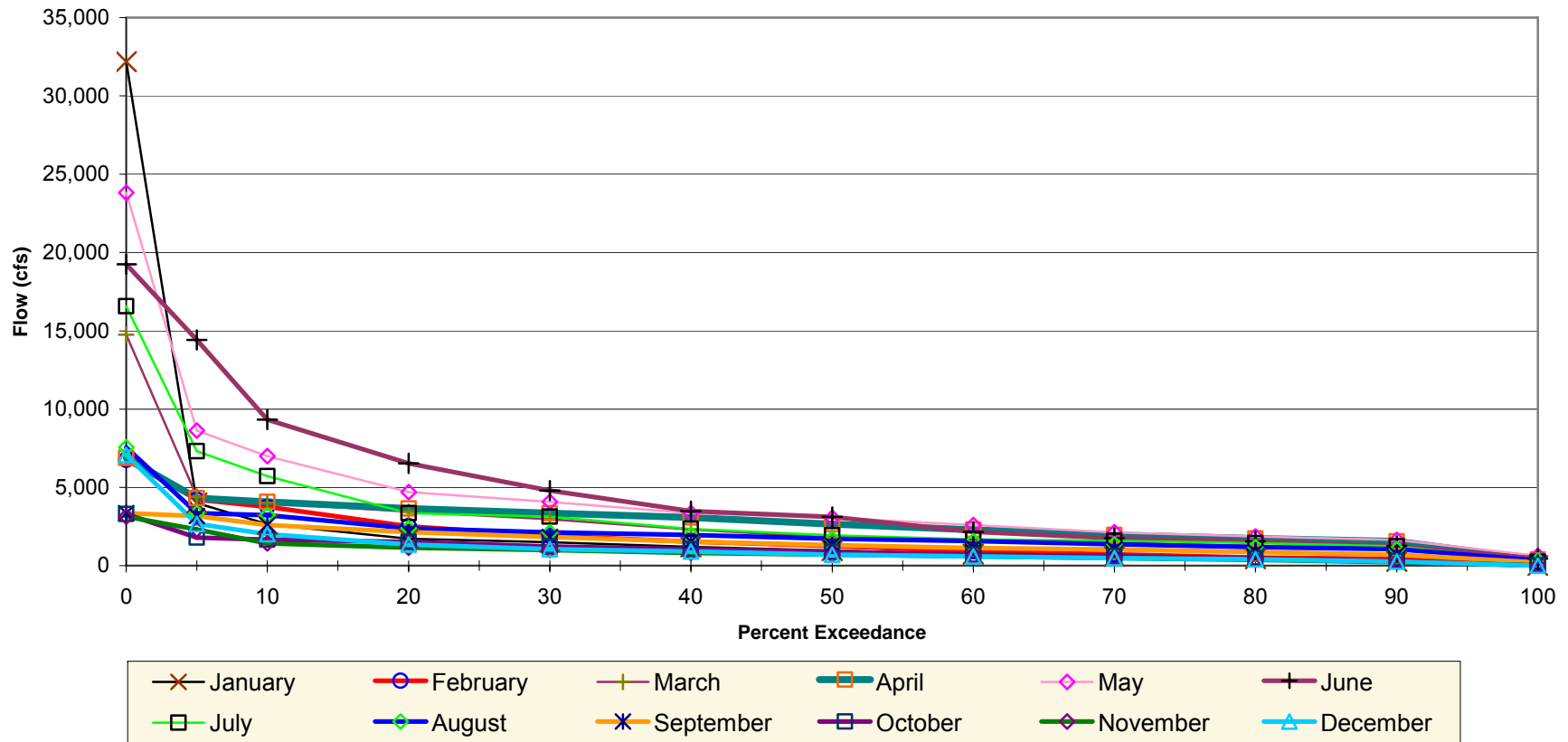

Note: Flows represent total available flow at Dam 6 and were derived by subtracting the minimum instream flow required downstream of Dam 6 (3 cfs) from the sum of the mean daily flows in the San Joaquin River downstream of Dam 6 (USGS Gage No. 11238600) and the throughput at Powerhouse No. 3 (USGS Gage No. 11241800). The period of record used for this analysis was October 1, 1982 to September 30, 1983 and October 1, 1984 to September 30, 2002.

Figure B-2. Monthly Flow Exceedance Curves at Dam 6.

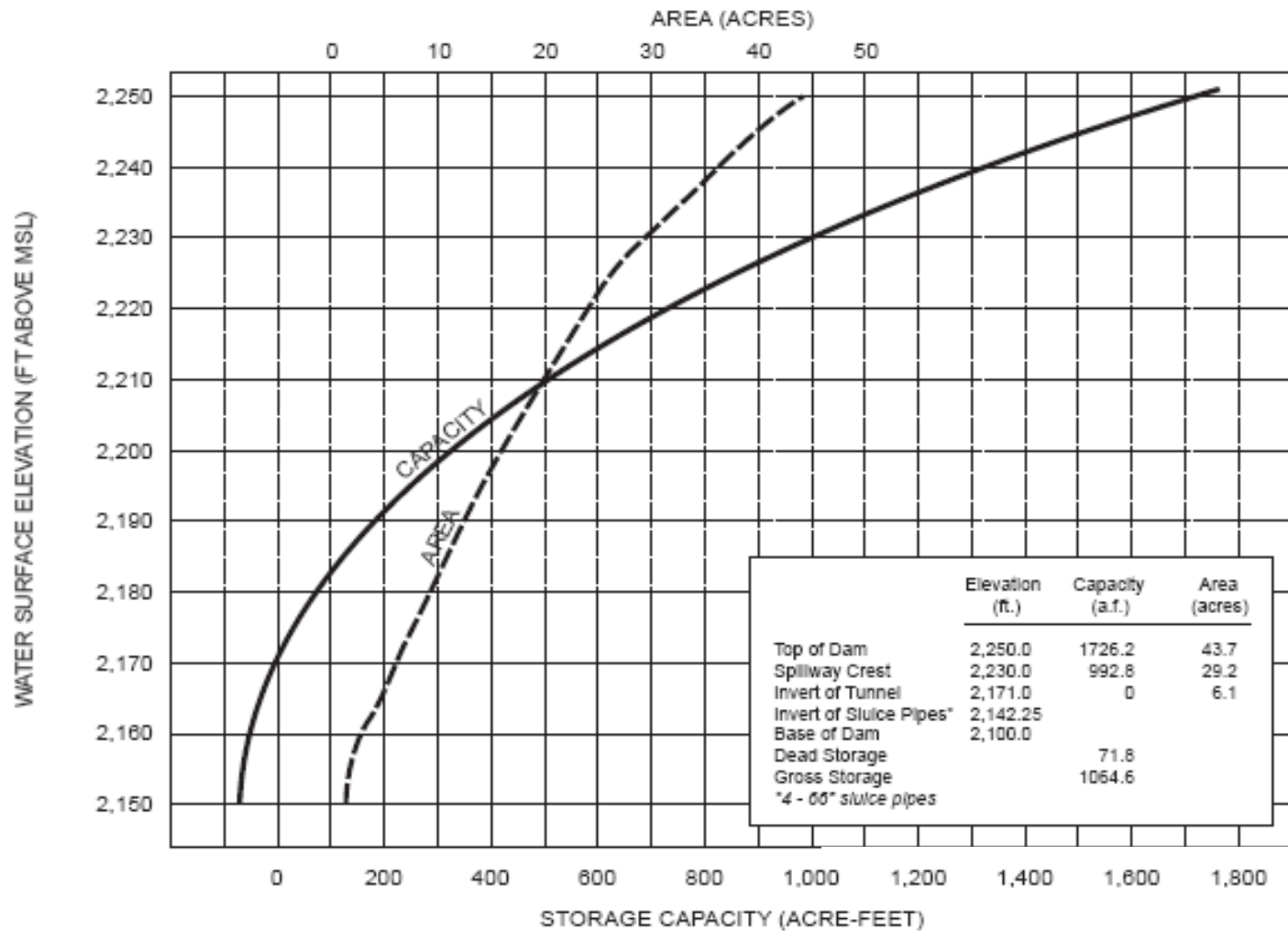

Figure B-3. Area and Capacity Curves at Powerhouse No. 3 Forebay.

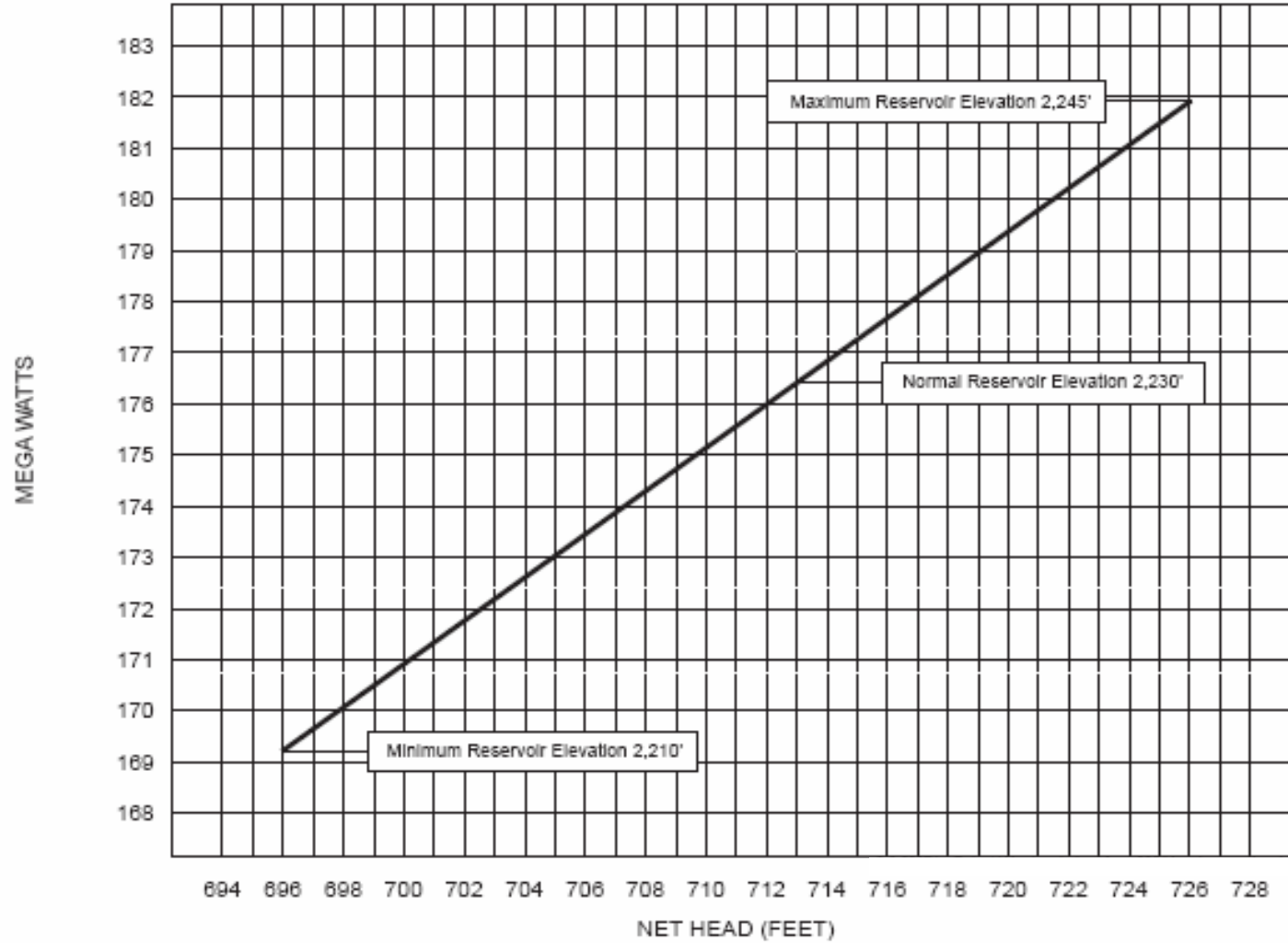

Figure B-4. Estimated Powerplant Capability Versus Head at Powerhouse No. 3.

SOUTHERN CALIFORNIA EDISON COMPANY

BEFORE THE

FEDERAL ENERGY REGULATORY COMMISSION

APPLICATION FOR NEW LICENSE

BIG CREEK NO. 3
(FERC Project No. 120)

EXHIBIT C: CONSTRUCTION HISTORY

CONTAINS PUBLIC INFORMATION

FEBRUARY 2007

Copyright 2007 by Southern California Edison Company. All rights reserved. No part of this publication may be reproduced, stored in a retrieval system, or transmitted, in any form or by any means, electronic, mechanical, photocopying, recording or otherwise, without the prior written permission of the Southern California Edison Company.

Exhibit C Construction History and Proposed Construction Schedule

Exhibit C is a construction history and proposed construction schedule for the project. The construction history and schedules must contain:

- (1) If the application is for an initial license, a tabulated chronology of construction for the existing projects structures and facilities described under paragraph (b) of this section (Exhibit A), specifying for each structure or facility, to the extent possible, the actual or approximate dates (approximate dates must be identified as such) of:
 - (i) Commencement and completion of construction or installation;
 - (ii) Commencement of commercial operation; and
 - (iii) Any additions or modifications other than routine maintenance; and
- (2) If any new development is proposed, a proposed schedule describing the necessary work and specifying the intervals following issuance of a license when the work would be commenced and completed.

(1) **Construction History**

- (i) This Application is for a new license and not for an initial license. Southern California Edison Company (SCE) provides the following construction history: the Project was constructed between 1921 and 1923. The Project was designed and constructed by SCE. Construction of Tunnel No. 3 commenced in Fall 1921 and was completed on August 26, 1923, construction of Powerhouse No. 3 began on June 5, 1922 and was completed in 1923, and construction of Dam 6 began in fall 1922 and was completed on March 18, 1923.
- (ii) The first generating unit (Unit 2) of Big Creek Powerhouse No. 3 commenced operation on September 30, 1923. Generating Units Nos. 1 and 3 were placed into operation on October 3, 1923 and October 5, 1923, respectively. Generating Unit 4 began operation on April 28, 1948. Unit 5 began operation on February 24, 1980.
- (iii) The Project has undergone the following upgrades and modifications since start-up:
 - In 1938, the lower parts of the bare rock abutments situated immediately downstream from the dam were reinforced with rock bolts and gunite to protect against impacts from spill events.

- In 1938, the 72-inch slide gates on the downstream face of Dam 6 were installed. These slide gates are used to control flow through the four 66-inch diameter steel sluice pipes, which pass through the base of the dam.
- In 1940, the 100-inch slide gates on the upstream face of the dam were installed. These slide gates are used in conjunction with the 72-inch slide gates on the downstream face of the dam to control flow through the four 66-inch diameter steel sluice pipes which pass through the base of the dam.
- In 1942, the Unit 3 generator was rewound.
- In 1943, the Unit 2 generator was rewound and upgraded from 28,000 kVA to 34,000 kVA.
- In 1944, the Unit 1 generator was rewound and upgraded from 28,000 kVA to 34,000 kVA.
- In 1945, the Unit 3 generator was rewound and upgraded from 28,000 kVA to 34,000 kVA.
- In 1948, generating Unit 4 was added to Powerhouse No. 3.
- In 1979, the Unit 1 generator was rewound.
- In 1979, the Unit 3 generator was rewound.
- In 1979, plates were removed from the intake apertures at the power intake structure in order to increase flow through Tunnel No. 3.
- In 1979, a polysulfide patch was placed on the left side of the upstream face of the dam (approximately 20 feet below the dam crest) to eliminate water leakage in this area.
- In 1979, the No. 3 bank of the main transformer was replaced.
- In 1980, generating Unit 5 was added to Powerhouse No. 3.
- In 1981, a steel plate silt barrier was constructed against the upstream face of the power tunnel intake to reduce the entrainment of sediment that was occurring following the start-up of Unit 5.
- In 1982, the Unit Nos. 1 and 3 turbines were de-rated from 42,500 HP to 41,300 HP.
- In 1982, the Powerhouse turbine runners for Units 1 and 3 were replaced with cast stainless steel runners.

- In 1983, the Unit 2 generator was rewound.
- In 1983, the Powerhouse turbine runners for Unit 2 were replaced with cast stainless steel runners and the turbine was de-rated from 42,500 HP to 41,300 HP.
- In 1985, the Powerhouse turbine runners for Unit 4 were replaced with cast stainless steel runners and the turbine was upgraded from 45,000 HP to 49,500 HP.
- In 1985, the Unit 4 generator was rewound and upgraded from 35,000 kVA to 40,000 kVA.
- Between 1989 and 1999, the governor oil pressure pumps for units 1, 2, 3 and 4 were replaced with Woodward screw type pumping units with electric unloader valves, associated sumps, and pressure tanks.
- In 1994, an “emergency” generator was placed into operation within Powerhouse 3.
- In 1995, the Unit 1 cooling water piping was replaced.
- In 1996, the No. 1 bank of the main transformer was replaced.
- In 1997, the No. 2 bank of the main transformer was replaced.
- In 1997, the Unit 4 generator was rewound.
- In 1998, the gates associated with the Dam 6 low level outlet works were extensively rehabilitated.
- In 1999, the control system was automated.
- In 2000, the Unit 3 & 4 fire suppression system was replaced.
- In 2001, the Unit 5 excitation system was replaced.
- In 2003, the #1 transformer bank was replaced.
- In 2003, a hydrotrac monitoring system was installed on Unit 4.
- In 2003, the turbine shut-off valve was replaced.
- In 2003, a plant annunciator was installed.
- In 2004, the low voltage switchgear was replaced.

(2) **New Development**

This is an existing project, however new construction activities are proposed at this time to implement the higher Minimum Instream Flow release at Dam 6 contained in the Proposed Action. No other construction activities are planned, except those that occasionally arise during the course of routine operation and maintenance of the Project.

SCE will evaluate the likely construction approach, and access needs to determine the appropriate infrastructure modification and to complete the preliminary engineering work for the Dam 6 modification. Based on this preliminary work, SCE will obtain necessary permits from resource agencies other than FERC prior to construction of the infrastructure modification. The Dam 6 modification will require the installation of a release structure. The schedule for this work is estimated as follows: preliminary engineering and site evaluation would be conducted in 2008; permitting and continued engineering would be conducted in 2009; continued engineering and equipment ordering would be conducted in 2010; and the construction would begin in 2011 and possibly continue into 2012.

SOUTHERN CALIFORNIA EDISON COMPANY

BEFORE THE

FEDERAL ENERGY REGULATORY COMMISSION

APPLICATION FOR NEW LICENSE

BIG CREEK NO. 3
(FERC Project No. 120)

EXHIBIT D: PROJECT COSTS AND FINANCING

CONTAINS PUBLIC INFORMATION

FEBRUARY 2007

Copyright 2007 by Southern California Edison Company. All rights reserved. No part of this publication may be reproduced, stored in a retrieval system, or transmitted, in any form or by any means, electronic, mechanical, photocopying, recording or otherwise, without the prior written permission of the Southern California Edison Company.

Exhibit D Project Costs and Financing

Exhibit D is a statement of costs and financing. The statement must contain:

- (1) If the application is for an initial license, a tabulated statement providing the actual or approximate original cost (approximate costs must be identified as such) of:
 - (i) Any land or water right necessary to the existing project; and
 - (ii) Each existing structure and facility described under paragraph (b) of this section (Exhibit A).
- (2) If the Applicant is a licensee applying for a new license, and is not a municipality or a state, an estimate of the amount which would be payable if the project were to be taken over pursuant to section 14 of the Federal Power Act upon expiration of the license in effect [see 16 U.S.C. 807], including:
 - (i) Fair value;
 - (ii) Net investment; and
 - (iii) Severance damages.
- (3) If the application includes proposals for any new development, a statement of estimated costs, including:
 - (i) The cost of any land or water rights necessary to the new development; and
 - (ii) The cost of the new development work, with a specification of:
 - (A) Total cost of each major item;
 - (B) Indirect construction costs such as costs of construction equipment, camps, and commissaries;
 - (C) Interest during construction; and
 - (D) Overhead, construction, legal expenses, taxes, administrative and general expenses, and contingencies.
- (4) A statement of the estimated average annual cost of the total project as proposed specifying any projected changes in the costs (life-cycle costs) over the estimated financing or licensing period if the applicant takes such changes into account, including:
 - (i) Cost of capital (equity and debt);
 - (ii) Local, state, and Federal taxes;
 - (iii) Depreciation or amortization;

- (iv) Operation and maintenance expenses, including interim replacements, insurance, administrative and general expenses, and contingencies; and,
- (v) The estimated capital cost and estimated annual operation and maintenance expense of each proposed environmental measure.
- (5) A statement of the estimated annual value of project power, based on a showing of the contract price for sale of power or the estimated average annual cost of obtaining an equivalent amount of power (capacity and energy) from the lowest cost alternative source, specifying any projected changes in the cost of power from that source over the estimated financing or licensing period if the applicant takes such changes into account.
- (6) A statement specifying the sources and extent of financing and annual revenues available to the applicant to meet the costs identified in paragraphs (e) (3) and (4) of this section.
- (7) An estimate of the cost to develop the license application;
- (8) The on-peak and off-peak values of project power, and the basis for estimating the values, for projects which are proposed to operate in a mode other than run-of-river; and
- (9) The estimated average annual increase or decrease in project generation, and the estimated average annual increase or decrease of the value of project power, due to a change in project operations (*i.e.*, minimum bypass flows; limits on reservoir fluctuations).

(1) Original Cost

Original cost of Project construction and obtaining land and water rights does not apply because the Project, which includes Big Creek 3 powerhouse, is not an application for an initial license and all necessary water rights and privately-owned lands have already been obtained.

(i) Not Applicable.

(ii) Not Applicable.

(2) Takeover Cost

It is the intent of SCE to continue to operate the Project upon receipt of a new license. If the Project were to be taken over at the expiration of the existing license, the following values would apply.

(i) The fair value of the Project is estimated to be \$411.9 million in 2006 dollars.

The fair value of the project was determined by calculating the net benefits realized by customers from a revenue requirement perspective. The calculation nets the full capital recovery and operating costs against the energy and capacity benefits of the project. Energy benefits are defined as the value of replacement marginal-cost market energy. Capacity benefits are defined as the deferral value of a combustion turbine (CT), given the least-cost characteristics of a CT for a capacity-only product with no associated energy benefits. These values are calculated on an annual basis and present-valued to determine the fair value of the project.

- (ii) The Net Investment of the Project was \$37,174,159 as of December 31, 2005.
- (iii) The severance value for the 824,081 MWh of annual generation is \$411.9 million and equal to the Fair Value discussed above in D(2)(ii) (also see Attachment D-1).

(3) Cost of New Development

The costs of new development do not apply because this Application does not include any such proposals. Only upgrades to existing facilities are planned and these will be performed during routine maintenance, or as planned capital replacement, or as structural modifications consistent with any new license requirements. Infrastructure changes required to implement environmental measures are discussed below in D(4)(v) (also see Attachment D-2).

- (i) Not Applicable.
- (ii) Not Applicable.
 - (A) Not Applicable.
 - (B) Not Applicable.
 - (C) Not Applicable.
 - (D) Not Applicable.

(4) Cost of Financing

The annual costs for this Project include expenses for Operations and Maintenance (O&M) as well as capital improvement work. The work currently scheduled for this Project is plant upgrades and maintenance, not “new development.”

- (i) The current SCE Cost of Capital is listed below:

Long-Term Debt	3.14%
Preferred Equity	0.75%
Common Equity	6.11%
Total Cost of Capital	10.00%

- (ii) Property Taxes associated with the Project for 2005 were \$380,846. State and Federal income taxes are computed for all of the SCE Hydro assets combined and no amount is specifically designated for this individual Project.
- (iii) Depreciation for this Project for 2005 was \$1,292,746.
- (iv) The direct (O&M) expenses for this Project are \$6,750,857, which is an estimated annualized value for the life of the license. Approximately \$456,523 of these O&M expenses are represented by annual fees that are detailed in Exhibit H(b)(9). Additional expenses not mentioned above include Administrative and General (A&G) expenses. These expenses are calculated for all of the SCE Hydro assets combined. An approximation of A&G expenses is equal to 1.25% times the Net Plant Investment or \$464,677 per year.
- (v) The estimated capital cost and estimated annual operation and maintenance expense of each proposed environmental measure is listed in Attachment D-2 and totals \$636,506 as an annualized value.

(5) Value of Project Power

SCE procures energy and related products to cover its “net-short” energy requirements for its electricity customers. The “net-short” position is defined as the condition when the energy required to meet customer demand exceeds the energy that SCE can provide from its owned or contracted resources.

The projected annual power value is determined by estimating the cost of replacing the energy and capacity provided by the Project at SCE’s current forecast of the marginal cost for energy and capacity. The estimated annual amount of energy produced from the Project was derived from a 15-year annual average of historical production from 1991 to 2005.

The amount of average annual replacement energy (MWh’s) was multiplied by the marginal energy cost forecast. The dependable capacity of the Project was multiplied by the marginal capacity cost forecast. The sum of the replacement energy and capacity costs is the total cost that SCE would expect to incur to replace the power being provided by this Project. The generation marginal costs used in these calculations were obtained from SCE’s 2006 General Rate Case (GRC) filing. Since the forecast does not include information beyond

2008, it is assumed that the costs will increase according to the Gross Domestic Product (GDP) Price Index escalation. SCE used an estimate of escalation from Global Insight (formerly DRI-WEFA) for the years beyond 2008.

The Project's forecasted power value for 2009 is \$56.6 million. When the power value is escalated for the expected 44-year term of the license and discounted at the SCE cost of capital, it yields a net present value of \$559.4 million in 2006 dollars. The levelized annual value of the energy benefits is \$56.6 million (see Attachment D-3).

(6) Sources of Financing and Revenues

As previously discussed in Exhibit D(3), there is no major new development planned for the Project. As such, there is no need to acquire special financing for any major capital work.

SCE previously filed a 2006 GRC with the California Public Utilities Commission (CPUC) in September 2005, which was approved in May of 2006. Included in this Rate Case filing were the generation-related O&M expenses as well as A&G expenses. The 2006 GRC filings included the expected costs for the years of 2006–2008, which are associated with the operation and maintenance of all the SCE Hydro assets, as well as the costs associated with any anticipated incremental capital additions. SCE is preparing to file a 2009 GRC Notice of Intent (NOI) with the CPUC in 2007. Assuming that the 2009 Rate case is approved, the capital and O&M expenses necessary for continued operation of the Projects will be collected through those approved rates. Those approved rates will include costs associated with license condition requirements that might be imposed upon the Projects in this license application in the years 2009-2011.

This Project is operated as a component of the entire Hydro Generation Division, which is part of the Power Production Department of SCE. The O&M expenses for this Project are therefore not wholly estimated at the division or department level, as the departmental costs are usually extrapolated from historical costs. Any financing charges required for individual projects would normally be included in the overall department budget and would not be directly attributable to the individual Project.

(7) License Application Development Cost

The cost incurred for this Project's FERC license Application through December, 2006 is approximately \$5,310,000. These costs include development of the license including portions of the Amended Preliminary Draft Environmental Analysis (APDEA), which includes Projects 2085, 2175, 67, and 120 as part of the Alternative Licensing Process (ALP) started in 2000.

(8) Value of On-Peak and Off-Peak Project Power

The on-peak and off-peak power values for the Project are based upon the 2006 energy price of \$49.40 per megawatt-hour (MWh) and the 2006 capacity price of \$69.70 per kilowatt-year (kW-yr). In 2007, the on-peak period energy price is \$56.63/MWh and the associated off-peak energy price is \$42.48/MWh. The distribution of the total power value is based on the ratios of on-peak to off-peak energy and capacity values. Energy value is distributed between on- and off-peak based on ratios developed while creating hourly fundamental energy price forecasts. Capacity value is distributed based on SCE's relative loss-of-load probability factors. Both sets of factors are consistent with those presented in Phase 2 of SCE's 2006 General Rate Case.

Attachment D-4 provides the average annual Project generation for dry, normal, and wet year categories. The total generation is divided into on-peak and off-peak generation. The percentages of time that the powerhouse operated in on-peak and off-peak generation modes was calculated using hourly generation data from the years 2001 (dry), 2000 (normal), and 2005 (wet). These calculated percentages of on-peak and off-peak powerhouse operation were applied to average annual generation to determine the average generation value of on-peak and off-peak generation in megawatt-hours. This analysis was conducted for dry, normal and wet years as defined in the footnote to the Attachment D-4.

(9) Effects of Changes in Project Operations

Under the Proposed Action, it is estimated that the average annual project generation will decrease by 19,841 MWh, resulting in a net reduction in the value of project power of approximately \$1,040,000 (this is an annualized value in 2006\$ based on the anticipated power generation over a projected 44-year license term).

ATTACHMENT D-1

FERC Project No. 120 - Fair Value

ATTACHMENT D-1

Big Creek 3 - Project 120 Fair Value

Revenue Requirement Net Present Value Benefit \$411,897 (In \$2006)
(In \$Thousands)

Year	Project Costs (\$)	Energy Benefits (\$)	Capacity Benefits (\$)	Net Benefits (\$)
2006	0	0	0	0
2007	0	0	0	0
2008	0	0	0	0
2009	9,078	43,178	13,447	47,547
2010	10,389	44,054	13,720	47,385
2011	11,693	44,996	14,013	47,317
2012	13,236	45,936	14,306	47,006
2013	14,154	46,856	14,593	47,296
2014	14,884	47,765	14,876	47,756
2015	15,614	48,662	15,155	48,203
2016	16,542	49,555	15,433	48,447
2017	17,000	50,439	15,709	49,148
2018	17,747	51,299	15,976	49,529
2019	18,463	52,229	16,266	50,032
2020	19,208	53,192	16,566	50,550
2021	19,935	54,186	16,876	51,127
2022	20,681	55,198	17,191	51,708
2023	21,438	56,240	17,515	52,317
2024	22,180	57,297	17,844	52,962
2025	22,934	58,393	18,186	53,644
2026	23,804	59,521	18,537	54,254
2027	24,486	60,665	18,893	55,072
2028	25,308	61,823	19,254	55,768
2029	26,108	63,030	19,630	56,552
2030	26,966	64,261	20,013	57,309
2031	27,848	65,506	20,401	58,058
2032	28,785	66,764	20,793	58,771
2033	29,742	68,031	21,187	59,477
2034	30,709	69,321	21,589	60,200
2035	31,717	70,624	21,995	60,902
2036	32,885	71,955	22,409	61,479
2037	33,726	73,310	22,831	62,415
2038	34,679	74,691	23,261	63,273
2039	35,573	76,098	23,700	64,224
2040	36,581	77,531	24,146	65,095
2041	37,710	78,991	24,601	65,882
2042	38,993	80,479	25,064	66,550
2043	40,381	81,995	25,536	67,150
2044	41,886	83,539	26,017	67,671
2045	43,474	85,113	26,507	68,147
2046	46,534	86,716	27,006	67,189
2047	50,477	88,349	27,515	65,387
2048	55,142	90,013	28,033	62,905
2049	60,564	91,709	28,561	59,706
2050	67,543	93,436	29,099	54,993
2051	77,763	95,196	29,648	47,080
2052	81,743	96,989	30,206	45,453
Total	\$1,376,307	\$2,935,134	\$914,106	\$2,472,934
NPV	\$147,469	\$426,530	\$132,837	\$411,897

(All above are \$Thousands)

Assumptions:

Energy and Capacity value per Appendix D-2
Project costs are based on Revenue Requirements
SCE Cost of Capital: 10.00%
License Life: 44 years

ATTACHMENT D-2

Cost of Environmental Measures Recommended in the Proposed Action and Resulting Reduction in Annual Energy Benefits by Project for the Big Creek No. 3 Project (FERC Project No. 120)

Attachment D-2. Cost of Environmental Measures Recommended in the Proposed Action and Resulting Reduction in Annual Energy Benefits by Project for the Big Creek No. 3 Project (FERC Project No. 120).

Environmental Measures	Year(s) Implemented	Capital and One-Time Costs (2006\$)	Annual Costs Including O&M (2006\$)	Annualized Costs (2006\$)	Reduction in Annual Energy Benefits (2006\$)
WATER AND AQUATIC RESOURCES					
Implement New Minimum Instream Flow Releases	3-46		\$3,000	\$414	\$1,040,000
Maintain Existing and New Gaging Stations	3-46		\$100,000	\$13,802	
Complete Required Infrastructure Modifications (MIF releases and gaging)					
Dam 6 Infrastructure Modifications	4-7	\$2,500,000		\$156,450	
Implement Monitoring Program					
Temperature	8-12	\$100,000	\$40,000	\$12,380	
Temperature (telemetry)	13-17		\$25,000	\$4,121	
Temperature (Hardhead and DO Study)	5,7		\$50,000	\$5,589	
Flow	3-46		\$25,000	\$22,578	
Fish	3,10,20,30,40		\$50,000	\$7,176	
Implement Sediment Management Plan					
Dam 6 (Flush) and V* monitoring	Every 5th year, beginning 2012		\$10,000	\$2,208	
Dam 6 (sediment removal)	Every 10th year, beginning 2012		\$100,000	\$22,083	
Attend Annual Consultation Meeting	3-46		\$500	\$452	
TERRESTRIAL RESOURCES					
Implement Wildlife Habitat Enhancement	3-46		\$2,000	\$1,806	
Implement Management Plans					
Bald Eagle	3, 7, 12, 17, 22, 27, 32, 37, 42		\$10,000	\$2,234	
VELB	3-46		\$13,000	\$11,741	
Vegetation and Integrated Pest	3-46		\$20,000	\$18,063	
Implement Proposed License Articles (Special-status Species, Bats)	3-46		\$6,000	\$5,419	
Implement Environmental Programs (Environmental Training, ESAP, Avian, Noxious Weed, NHSSSIP, Environmental Compliance)	3-46	\$25,000	\$2,500	\$4,065	
Attend Annual Consultation Meeting	3-46		\$500	\$452	
RECREATION RESOURCES					
Implement Recreation Management Plan					
Rehabilitation of Existing Recreation Facilities	13-22	\$50,000		\$1,413	
Prepare Report on Recreation Resources (every 6 years)	8, 14, 20, 26, 38		\$5,000	\$557	
Dissemination of Flow Information (whitewater boating)	3-46		\$5,000	\$4,516	
Attend Annual Consultation Meeting	3-46		\$500	\$452	
LAND MANAGEMENT					
Implement Management Plans					
Transportation System Plan	3-46		\$12,000	\$12,882	
Fire Plan	3-46		\$500	\$452	
Spill Prevention Control and Countermeasure Plans	3-46		\$500	\$452	
Attend Annual Consultation Meeting	3-46		\$500	\$452	
Transportation System Plan Labor	3-46		\$277,500	\$250,620	
Transportation System Plan Equipment & Materials	3-46		\$72,800	\$65,748	
CULTURAL RESOURCES					
Implement a Historic Properties Management Plan	3-46	\$41,000	\$4,000	\$6,577	
Implement Environmental Programs (Environmental, Cultural Awareness)	3-46		\$1,000	\$903	
Attend Annual Consultation Meeting	3-46		\$500	\$452	
TOTAL PROJECT 120 COST			\$837,300	\$636,506	\$1,040,000

ATTACHMENT D-3

FERC Project No. 120 – Total and Annual Value

ATTACHMENT D-3

Big Creek 3 Power - Project 120 Total & Annual Value						
		Power Present Value		\$559,366 (In \$2006), (In \$Thousands)		
		Power Levelized Value		\$56,650 (In \$2006), (In \$Thousands)		
Year	Total Value of Power (\$)	Energy Value (\$)	Capacity Value (\$)	Energy Price (\$/MWh)	Capacity Price (\$/kW-yr)	Power Escalation Factor
2006	0			49.40	69.70	2.92%
2007	0			50.41	71.13	2.05%
2008	0			51.38	72.49	1.92%
2009	56,625	43,178	13,447	52.40	73.93	1.98%
2010	57,775	44,054	13,720	53.46	75.43	2.03%
2011	59,010	44,996	14,013	54.60	77.04	2.14%
2012	60,242	45,936	14,306	55.74	78.65	2.09%
2013	61,449	46,856	14,593	56.86	80.22	2.00%
2014	62,641	47,765	14,876	57.96	81.78	1.94%
2015	63,817	48,662	15,155	59.05	83.32	1.88%
2016	64,989	49,555	15,433	60.13	84.85	1.84%
2017	66,148	50,439	15,709	61.21	86.36	1.78%
2018	67,276	51,299	15,976	62.25	87.83	1.71%
2019	68,495	52,229	16,266	63.38	89.42	1.81%
2020	69,758	53,192	16,566	64.55	91.07	1.84%
2021	71,062	54,186	16,876	65.75	92.77	1.87%
2022	72,389	55,198	17,191	66.98	94.51	1.87%
2023	73,755	56,240	17,515	68.25	96.29	1.89%
2024	75,142	57,297	17,844	69.53	98.10	1.88%
2025	76,579	58,393	18,186	70.86	99.98	1.91%
2026	78,058	59,521	18,537	72.23	101.91	1.93%
2027	79,558	60,665	18,893	73.62	103.87	1.92%
2028	81,076	61,823	19,254	75.02	105.85	1.91%
2029	82,659	63,030	19,630	76.48	107.91	1.95%
2030	84,275	64,261	20,013	77.98	110.02	1.95%
2031	85,907	65,506	20,401	79.49	112.15	1.94%
2032	87,556	66,764	20,793	81.02	114.31	1.92%
2033	89,219	68,031	21,187	82.55	116.48	1.90%
2034	90,910	69,321	21,589	84.12	118.69	1.90%
2035	92,619	70,624	21,995	85.70	120.92	1.88%
2036	94,364	71,955	22,409	87.31	123.20	1.88%
2037	96,141	73,310	22,831	88.96	125.52	1.88%
2038	97,952	74,691	23,261	90.64	127.88	1.88%
2039	99,797	76,098	23,700	92.34	130.29	1.88%
2040	101,677	77,531	24,146	94.08	132.74	1.88%
2041	103,592	78,991	24,601	95.85	135.24	1.88%
2042	105,543	80,479	25,064	97.66	137.79	1.88%
2043	107,531	81,995	25,536	99.50	140.39	1.88%
2044	109,557	83,539	26,017	101.37	143.03	1.88%
2045	111,620	85,113	26,507	103.28	145.72	1.88%
2046	113,722	86,716	27,006	105.23	148.47	1.88%
2047	115,865	88,349	27,515	107.21	151.27	1.88%
2048	118,047	90,013	28,033	109.23	154.11	1.88%
2049	120,270	91,709	28,561	111.29	157.02	1.88%
2050	122,536	93,436	29,099	113.38	159.97	1.88%
2051	124,844	95,196	29,648	115.52	162.99	1.88%
2052	127,195	96,989	30,206	117.69	166.06	1.88%

(All above are \$Thousands)

Assumptions:

2007 Energy Price (\$/MWh):	50.41
2007 Capacity Price (\$/kW-yr):	71.13
Big Creek 3 Generation (MWh):	824,081
Big Creek 3 Dependable Capacity (MW):	181.9
2009 Power Value (In \$Thousands):	\$56,625
SCE Cost of Capital:	10.00%
License Life:	44 years
Power Escalation Factor:	GDP Index (Global Insight)

ATTACHMENT D-4

FERC Project No. 120 – Average On-Peak and Off-Peak Generation in MWh's for Dry, Normal and Wet Years

ATTACHMENT D-4

**Average On-Peak and Off-Peak Generation
in MWh's for Dry, Normal and Wet Years⁽¹⁾
(FERC Project No. 120)**

Type of Year	Average Generation	On-Peak Generation	Off-Peak Generation
Dry	573,557	398,810	174,748
Normal	872,552	554,743	317,809
Wet	1,110,961	663,242	447,720

⁽¹⁾Project 120 receives inflow from the upstream Projects 2175, 67, and 2085 with runoff varying from a dry year to a wet year. The determination of a dry, normal, or wet year is made with the annual runoff for the San Joaquin River downstream at Friant Dam. The decision of whether the year is dry, normal, or wet is done with a 30%-40%-30% division of annual runoff volume for 128 years, through 2005. The data used to provide the 31-year averages above are from 1975 through 2005.

SOUTHERN CALIFORNIA EDISON COMPANY

BEFORE THE

FEDERAL ENERGY REGULATORY COMMISSION

APPLICATION FOR NEW LICENSE

BIG CREEK NO. 3
(FERC Project No. 120)

EXHIBIT H(A) GENERAL INFORMATION

CONTAINS PUBLIC INFORMATION

FEBRUARY 2007

Copyright 2007 by Southern California Edison Company. All rights reserved. No part of this publication may be reproduced, stored in a retrieval system, or transmitted, in any form or by any means, electronic, mechanical, photocopying, recording or otherwise, without the prior written permission of the Southern California Edison Company.

Exhibit H(a) General Information

Exhibit H(a) describes information to be provided pursuant to 18 CFR § 16.10(a):

- (1) A discussion of the plans and ability of the applicant to operate and maintain the project in a manner most likely to provide efficient and reliable electric service, including efforts and plans to:
 - (i) Increase capacity or generation at the project;
 - (ii) Coordinate the operation of the project with any upstream or downstream water resource projects; and
 - (iii) Coordinate the operation of the project with the applicant's or other electrical systems to minimize the cost of production.
- (2) A discussion of the need of the applicant over the short and long term for the electricity generated by the project, including:
 - (i) The reasonable costs and reasonable availability of alternative sources of power that would be needed by the applicant or its customers, including wholesale customers, if the applicant is not granted a license for the project;
 - (ii) A discussion of the increase in fuel, capital, and any other costs that would be incurred by the applicant or its customers to purchase or generate power necessary to replace the output of the licensed project, if the applicant is not granted a license for the project;
 - (iii) The effect of each alternative source of power on:
 - (A) The applicant's customers, including wholesale customers;
 - (B) The applicant's operating and load characteristics; and
 - (C) The communities served or to be served, including any reallocation of costs associated with the transfer of a license from the existing licensee.
- (3) The following data showing need and the reasonable cost and availability of alternative sources of power:
 - (i) The average annual cost of the power produced by the project, including the basis for that calculation;

- (ii) The projected resources required by the applicant to meet the applicant's capacity and energy requirements over the short and long term including:
 - (A) Energy and capacity resources, including the contributions from the applicant's generation, purchases, and load modification measures (such as conservation, if considered as a resource), as separate components of the total resources required;
 - (B) A resource analysis, including a statement of system reserve margins to be maintained for energy and capacity; and
 - (C) If load management measures are not viewed as resources, the effects of such measures on the projected capacity and energy requirements indicated separately;
- (iii) For alternative sources of power, including generation of additional power at existing facilities, restarting deactivated units, the purchase of power off-system, the construction or purchase and operation of a new power plant, and load management measures such as conservation:
 - (A) The total annual cost of each alternative source of power to replace project power;
 - (B) The basis for the determination of projected annual cost; and
 - (C) A discussion of the relative merits of each alternative, including the issues of the period of availability and dependability of purchased power, average life of alternatives, relative equivalent availability of generating alternatives, and relative impacts on the applicant's power system reliability and other system operating characteristics; and
- (iv) The effect on the direct providers (and their immediate customers) of alternate sources of power.
- (4) If an applicant uses power for its own industrial facility and related operations, the effect of obtaining or losing electricity from the project on the operation and efficiency of such facility or related operations, its workers, and the related community.
- (5) If an applicant is an Indian tribe applying for a license for a project located on the tribal reservation, a statement of the need of such tribe for electricity generated by the project to foster the purposes of the reservation.

- (6) A comparison of the impact on the operations and planning of the applicant's transmission system of receiving or not receiving the project license, including:
 - (i) An analysis of the effects of any resulting redistribution of power flows on line loading (with respect to applicable thermal, voltage, or stability limits), line losses, and necessary new construction of transmission facilities or upgrading of existing facilities, together with the cost impact of these effects;
 - (ii) An analysis of the advantages that the applicant's transmission system would provide in the distribution of the project's power; and
 - (iii) Detailed single-line diagrams, including existing system facilities identified by name and circuit number, that show system transmission elements in relation to the project and other principal interconnected system elements. Power flow and loss data that represent system operating conditions may be appended if applicants believe such data would be useful to show that the operating impacts described would be beneficial.
- (7) If the applicant has plans to modify existing project facilities or operations, a statement of the need for, or usefulness of, the modifications, including at least a reconnaissance-level study of the effect and projected costs of the proposed plans and any alternate plans, which in conjunction with other developments in the area would conform with a comprehensive plan for improving or developing the waterway and for other beneficial public uses as defined in section 10(a)(1) of the Federal Power Act.
- (8) If the applicant has no plans to modify existing project facilities or operations, at least a reconnaissance-level study to show that the project facilities or operations in conjunction with other developments in the area would conform with a comprehensive plan for improving or developing the waterway and for other beneficial public uses as defined in section 10(a)(1) of the Federal Power Act.
- (9) A statement describing the applicant's financial and personnel resources to meet its obligations under a new license, including specific information to demonstrate that the applicant's personnel are adequate in number and training to operate and maintain the project in accordance with the provisions of the license.

- (10) If an applicant proposes to expand the project to encompass additional lands, a statement that the applicant has notified, by certified mail, property owners on the additional lands to be encompassed by the project and governmental agencies and subdivisions likely to be interested in or affected by the proposed expansion.
- (11) The applicant's electricity consumption efficiency improvement program, as defined under section 10(a)(2)(C) of the Federal Power Act, including:
- (i) A statement of the applicant's record of encouraging or assisting its customers to conserve electricity and a description of its plans and capabilities for promoting electricity conservation by its customers; and
 - (ii) A statement describing the compliance of the applicant's energy conservation programs with any applicable regulatory requirements.
- (12) The names and mailing addresses of every Indian tribe with land on which any part of the proposed project would be located or which the applicant reasonably believes would otherwise be affected by the proposed project.

(1) Efficient and Reliable Operation and Maintenance of Project

(i) Increased Capacity or Generation at the Project

Southern California Edison Company (SCE) currently has no plans to further increase capacity or generation at the Project.

(ii) Coordinate the Operation of the Project with any Upstream or Downstream Water Resource Projects

Project Operations

Operation of SCE's seven Federal Energy Regulatory Commission (Commission or FERC) licensed Projects in the Big Creek System (BCS) is managed from a watershed-wide perspective and on an individual project-by-project basis. The BCS consists of six major reservoirs (Thomas A. Edison, Florence, Huntington, Redinger, Shaver, and Mammoth Pool,) and nine powerhouses (Portal; Eastwood; Mammoth Pool; and Big Creek Powerhouse Nos. 1, 2, 2A, 3, 4, and 8). The operation of the BCS and the individual Projects is dependent on natural run-off, the operation of other components in the system, storage requirements of the Mammoth Pool Operating Agreement, the amount of generation required for SCE's customers, and the dispatching of energy in accordance with the California Independent System Operator requirements.

SCE operates the four Big Creek ALP projects within the BCS in accordance with FERC license conditions, which includes MIF release requirements from diversions and impoundments.

The management of water through the BCS and specifically the four Big Creek Alternative Licensing Process (ALP) Projects routes water between Projects in a manner that best meets the operational constraints that are imposed either by contractual operating agreements (i.e., licenses, permits, etc.) or by physical limitations of the Project infrastructure. The BCS is subject to several operating constraints including the following: (1) available water supply; (2) electrical system requirements; (3) both planned and unplanned maintenance outages; (4) storage limits (including both recreation minimums and year-end carryover maximums); (5) both minimum and maximum release limits (from storage); (6) various provisions contained in water rights agreements; and (7) California Independent System Operator requirements.

Water Rights and Contractual Obligations

Each of SCE's Big Creek Hydroelectric Projects either has separate water rights or shares one or more water rights with other projects for the diversion, use, and storage of water. The majority of the water rights are for non-consumptive uses associated with the generation of power. A few locations, such as SCE's administrative offices and company housing near Big Creek No. 1 Powerhouse have minor consumptive water rights. SCE does not hold water rights for the consumptive use of water by any party other than SCE, nor does SCE sell any water rights associated with the hydropower projects to other parties.

SCE's water rights were obtained pursuant to state law and a majority of the water rights are documented by licenses and permits issued to SCE, or its predecessors, by the State Water Resources Control Board (State Water Board). Additional water rights were obtained through appropriation of water prior to the implementation of the Water Commission Act of 1914, and by prescriptive use against other parties. SCE also holds other water rights as a riparian land owner, which authorizes SCE to divert and use water on land owned by SCE.

The water rights agreements contain stipulations that stem from the senior status of certain downstream water rights holders. Generally, any water right holder with senior rights began diverting water for consumptive purposes prior to SCE or its predecessors. To protect the rights of the downstream water rights holders, SCE entered into agreements that restrict the use of water within the BCS to non-consumptive purposes, i.e., hydroelectric generation. Certain agreements limit the length of time and amount of water that SCE can store in its Project reservoirs. In a few

instances, SCE's non-consumptive water use is a senior water right, and other water users hold junior water rights.

SCE operates its reservoirs consistent with the Mammoth Pool Operating Agreement (MPOA), which specifies cumulative reservoir storage constraints based on the computed natural run-off for the water year at Friant Dam. The MPOA between SCE and the U.S. Bureau of Reclamation (Bureau) specifies water storage and release requirements for the BCS reservoirs, which are upstream of Friant Dam (Millerton Reservoir) and the associated Central Valley Project water distribution system operated by the Bureau on behalf of the downstream irrigators. Millerton Reservoir is a major irrigation storage facility serving the central San Joaquin Valley agricultural community. Meetings between SCE, the Bureau, and the downstream irrigators are held following the March 1 run-off forecast each year, and periodically as needed, to coordinate and optimize hydropower production consistent with irrigation needs of the downstream agricultural users holding senior water rights and emergency flood control operations of Millerton Reservoir. The MPOA includes constraints on the annual and seasonal timing and volume of releases from SCE's reservoirs, maximum year-end storage allowed, and minimum seasonal flow from Dam No. 7 (release and diversion).

BCS Water Management

A key component of the annual water management plan for the BCS is the development of an annual run-off forecast. The annual run-off forecast is developed based on snow pack and precipitation data collected in the vicinity of the Project. This information is used along with assumptions about future median precipitation and air temperatures to produce a run-off forecast through the end of the water year (September 30). The forecast includes an estimate of both the timing and the quantity of water that will enter Project reservoirs during that run-off season. Snow pack and precipitation data are shared with the California Department of Water Resources (DWR) and the Bureau, who use it to develop individual forecasts of run-off volumes and declare water year types (critical, dry, below normal, above normal, or wet). The run-off forecast is a valuable tool for planning and ensuring compliance with the constraints of the MPOA (described above) and for planning purposes. A majority of the MPOA and other constraints are based on actual run-off volumes. The forecast also is used for directing future operational plans for: 1) instream flow release requirements; 2) reservoir recreational storage requirements; and 3) hydroelectric generation operations for the entire BCS.

The operation of the BCS is similar in all water year types in that water diverted from Project reservoirs and diversions is utilized to generate power. There are subtle differences, however, in the way that the Project

is operated during different water year types and during different conditions of state energy requirements.

Some of the BCS reservoirs generally spill in wet and above normal water years and are filled to maximum capacity when spill ceases. When the BCS reservoirs stop spilling, SCE is able to manage the system with available inflows and begin managing the water to meet electric supply requirements by providing both base load and peak cycling energy. In the upper basin area, water from the upper South Fork San Joaquin River drainage is stored in Florence Lake and water from Mono Creek drainage is stored in Lake Thomas A. Edison. Water is diverted from these two lakes and various other small backcountry diversions into Huntington Lake via the Ward Tunnel and the Mono-Bear Siphon. The volumes of water that can pass through Ward Tunnel and the siphon are limited by the physical size and layout of these conduits. Water deliveries to Huntington Lake are prioritized as follows: first priority is given to water from Florence Lake; second priority is given to water from Bear Diversion and Lake Thomas A. Edison; and third priority is given to water diverted from the small diversions at Camp 61 Creek, Camp 62 Creek, Chinquapin Creek and Bolsillo Creek. The water delivered to Huntington Lake may also pass through Portal Powerhouse at the exit of the Ward Tunnel depending upon the amount of water being transported.

BCS Power Generation

The BCS has three interlinked water chains or pathways through which water may be transported and used to produce power. The three water chains are:

- Huntington Water Chain: This chain consists of Portal Powerhouse, Powerhouse No. 1, Powerhouse No. 2, Powerhouse No. 8, Powerhouse No. 3, and Powerhouse No. 4.
- Shaver Water Chain: This chain consists of Portal Powerhouse, Eastwood Power Station, Powerhouse No. 2A, Powerhouse No. 8, Powerhouse No. 3, and Powerhouse No. 4.
- Mammoth Water Chain: This chain consists of Mammoth Pool Powerhouse, Powerhouse No. 3, and Powerhouse No. 4.

After passing through or bypassing the Portal Powerhouse, water entering Huntington Lake is directed to either the Huntington Chain, or the Shaver Chain. If the generation from the powerhouses of either chain is increased or decreased proportionally, the changes in load will have no effect on the MIF, or total levels of the storage reservoirs and forebays within the BCS. Changes in total loading conditions of the two chains can, however, affect Florence Lake and Lake Thomas A. Edison, and can

affect the amount of water leaving the project at Powerhouse No. 4. If generation from the powerhouses of either chain is changed disproportionately, the levels of Huntington Lake, Shaver Lake, and Redinger Lake can be increased or decreased.

Water from Big Creek Powerhouse Nos. 1 and 2 in the Huntington Chain joins water from the Shaver Chain, which has already passed through Eastwood Power Station and Big Creek Powerhouse No. 2A, at the Big Creek Powerhouse No. 2 and 2A Tailrace (Dam 5). Water from these two chains is then diverted through Big Creek Powerhouse No. 8, after which it joins the waters of the San Joaquin River coming from the Mammoth Chain at the Big Creek No. 8 Tailrace (Dam 6 Impoundment). Water from all three chains then continues through Big Creek Powerhouse Nos. 3 and 4.

Waters from the Middle Fork and North Fork San Joaquin River (SJR) drainages, and the South Fork SJR flows not diverted at Florence Lake, Lake Thomas A. Edison, Bear Creek Forebay, and the small backcountry diversions, are collected in Mammoth Pool Reservoir and become part of the Mammoth Chain. Mammoth Pool Powerhouse is usually run at maximum during the high flow or run-off period to prevent or delay spill at Mammoth Pool Reservoir.

For the most part, Portal Powerhouse, Eastwood Power Station, and Big Creek No. 4 Powerhouse operate independently of the other powerhouses in the BCS. Portal Powerhouse opportunistically uses water passing through the Ward Tunnel for power generation, but only operates efficiently at moderate flows through Ward Tunnel. Ward Tunnel flows outside the efficient flow range of Portal Powerhouse bypass Portal Powerhouse through the Howell Bunger (HB) valve into Huntington Lake. Eastwood Power Station generation normally occurs during the peak demand period of the day, unless water is being moved continuously from Huntington Lake to Shaver Lake to avoid spill at Huntington Lake or to increase storage at Shaver Lake for use during peak periods. Maintaining storage (water surface levels) to maintain recreational needs at Huntington Lake and above pump-back minimum water surface level in Shaver Lake are important considerations when planning operations at Eastwood Power Station. Big Creek Powerhouse No. 4 is the last power generation opportunity in the Big Creek System and therefore adjustments in the operation of the Powerhouse No. 4 will not affect other upstream powerhouses in the BCS.

Generally, the three water chains of the BCS are operated around the clock in the spring run-off period, except in dry water years. Operational flexibility is limited during normal run-off because the amount of water run-off available exceeds the combined generation and storage capacity of the project, resulting in water flowing over spillways or "spill."

After the end of the spill period, daily unit plant load schedules are established to maximize hydro resources during system peak load periods. When spring run-off is finished, if a powerhouse does not need to operate for water management, it is run preferentially during on-peak hours. Due to the nature of the energy market and SCE's resources, it is generally beneficial for the Big Creek Projects to provide power during on-peak hours, once the spring run-off has finished. Since the BCS powerhouses discharge to reservoirs or forebays, the peaking operations generally do not cause varying flows in bypass reaches. Energy load changes on these power generation chains will not affect the water surface elevation (WSE) or instream flows, as long as adjustments are made to match reservoir inflows and outflows. A proprietary computer model used for predicting inflow is also used to plan monthly flow of water through the Project to meet the operating constraints on the system while maximizing generation during the peak load periods. In addition, computer programming of load schedules to use the most efficient units first, further enhances these operating activities and improves system integrity and efficiency. These activities can ensure the efficient use and availability of hydroelectric generation resources from these reservoir storage plants.

Market constraints and pricing, as well as transmission constraints and weather, will affect generation and operations at the Big Creek Projects. Often during the spring run-off season there is a financial disadvantage for SCE to generate energy even though to avoid generation would cause spill to occur. A simplified description of the California energy market describes the Independent System Operator (ISO) as having the role of balancing energy demand and supply in the state. The ISO takes the energy demand forecast, the transmission system constraints, and the energy that is bid into the day-ahead market to determine the acceptable energy supply. The ISO then adjusts the supply load on a real-time basis to account for changing conditions. If the ISO believes that there is a surplus of energy available beyond that necessary to supply the grid, prices in the California energy market for additional energy could be negative. This situation would require SCE to pay for contributing additional energy.

Water Management of Big Creek No. 3 Project (FERC Project No. 120)

The Big Creek No. 3 Project Powerhouse, located on the San Joaquin River, is operated locally from the Big Creek No. 3 Powerhouse control room or remotely from the Big Creek dispatch center which serves as the main control center for the entire SCE Big Creek Hydroelectric System. The flow of water through the Big Creek No. 3 Project is dependent on natural run-off during periods of snowmelt and wet weather, and the operation of other components of the Big Creek Hydroelectric System that are located at higher elevations within the drainage. Big Creek

Powerhouse No. 3 is one of the last generating opportunities in each of the water chains listed above, as water is moved from Florence Lake, Edison Lake, Huntington Lake, Shaver Lake, Mammoth Pool, and various tributaries through the water chains. The Project receives water from the Dam 6 impoundment and discharges into Redinger Lake. The Powerhouse No. 3 Project operates in conjunction with the rest of the BCS in a stair step sequence of water chains.

The operation of the Powerhouse No. 3 Project is similar in all water year types in that water diverted into the Project from remote impoundments and diversions is utilized to generate power when the water is available. In wet years, the Project is generally run at full capacity beginning in May until the end of peak run-off, which typically occurs in late July. Once SCE gains control of inflows, powerhouse operation is managed to meet grid requirements by providing both base load and/or peak cycling energy. Project generation is greater during wet water years and the Dam 6 outlet works and spillway may be used to also bypass water around the powerhouse, if necessary.

In above normal water years, the Project is generally run at full capacity beginning in May until the end of peak run-off, which typically occurs in July. Some of the BCS reservoirs generally spill in above normal water years and are filled to maximum capacity until spill ceases. At that time, SCE gains control of inflows and begins managing powerhouse operations to meet grid requirements by providing both base load and/or peak cycling energy. The water flow through the Big Creek No. 3 Powerhouse is generally matched to the flow entering Dam 6.

During Dry Water Years, the Project may run at full capacity for a short duration in May and June. In some dry water years, the Project does not run at full capacity in order to fill the reservoirs to maximum capacity. Project generation is lower in dry water years and very little water, other than dam seepage and required MIF releases, bypasses the powerhouses.

Under the Proposed Action, water management would remain generally the same as existing operations.

(iii) Coordinate the Operation of the Project with Other Electrical Systems to Minimize the Cost of Production

SCE optimizes the use of the Project to provide maximum generation during run-off and peak demand periods. The entire set of SCE generation facilities is coordinated through the SCE Energy Control Center to maximize generation while minimizing economic and environmental costs. SCE bids power from its retained generation facilities into markets governed by the Independent System Operator (ISO). Thus, electrical

generation from the BCS and the four BC ALP Projects is coordinated with other generation throughout California.

(2) Need for the Project

The need for the Project is twofold as: (1) SCE needs the capacity of the Project to supply its customers; and (2) the value of the energy produced by the Project is greater than the costs associated with producing this energy. Continued operation of the Project will reduce the need for SCE to purchase replacement energy and capacity, which would be significantly more expensive than the production costs associated with the Project. In addition, the Project contributes to the fuel diversity of SCE's energy supply and is a significant hedge against the potential impacts of the volatile natural gas market.

The environmental value of the Project mainly consists of using a non-polluting renewable fuel resource to displace other forms of generation, such as gas-fired energy, that creates air pollution as well as depleting non-renewable resources. The Project is, however, too large to be included as an Eligible Renewable form of energy, based on accounting regulations in California, and thus does not assist SCE in meeting the goals of California's Renewable Portfolio Standard (CA Senate Bill 1078).

(i) Costs and Availability of Alternative Sources of Power

SCE is presently unable to supply energy to its entire customer load from SCE-owned generation resources for all hours.

Load management is not currently an option to replace the Project, as it might be able to supply capacity but cannot supply the amount of energy that this large hydroelectric facility produces. Energy efficiency is not a viable option, in place of this facility, because SCE is already planning on utilizing all of the available cost-effective energy efficiency programs. SCE was encouraged to, and eventually did, divest all of its natural gas generation facilities when the California market deregulation occurred in early 1998, therefore SCE does not have any deactivated or retired plants that can be restarted to replace this capacity and energy.

SCE must therefore purchase its unmet capacity and energy requirements from the existing market. Since SCE does not currently have the necessary resources, nor do we plan to develop sufficient resources to meet all our energy obligations, SCE would likely purchase "net short" customer load requirements from the market, either through bilateral transactions or through spot market purchases. It is estimated that the cost of replacement power would be approximately \$55.6 million per year in 2006(\$) and this cost would escalate in future years. This energy is expected to be readily available.

(ii) Increase in Fuel, Capital, and Other Costs

If the Project was not licensed, the replacement power could not be generated by SCE, but would be purchased from the market as discussed above. SCE would incur the costs associated with purchasing the replacement power for its customers. If firm energy contracts are purchased, the expected cost of those contracts is the same as above at approximately \$55.6 million per year in 2006(\$) and escalating thereafter.

If contracts are structured as tolling arrangements, where SCE provides the natural gas for a generator, SCE may be required to purchase the natural gas necessary for the contracted generator to produce this energy. It is estimated that the cost to purchase the gas and replace the energy provided by the Project would total \$62.7 million. This assumes an average of 10,000 Btu/kWh heat rate for replacement energy and the gas price is based on a five-day average of NYMEX natural gas forward prices (as of December 20, 2006) plus a Southern California Gas Company transportation charge. Costs associated with the Project not obtaining a new license would include the cost of obtaining contracts to replace the energy and capacity provided by the Project. There may also be some additional costs in purchasing ancillary services (such as spinning reserve) if these hydro resources cannot be used for those purposes. No estimate of those costs has been provided in this filing.

(iii) Effect of Alternative Sources of Power

The Project provides a stabilizing low-cost base of generation with high reliability and, with a dependable operating capacity of 181.35 MW, accounts for approximately 18% of the total hydroelectric capacity for SCE's Northern Hydroelectric Division. If a new license is not granted, it will have a significant impact on SCE's total hydroelectric energy capability.

(A) The Project provides lower cost energy to SCE's customers than the cost of replacement energy. This cost savings is not specifically assigned to any one class of customers, including wholesale customers. System generation serves all customers through a diverse transmission system and with a generation mix based on many different resources such as gas, coal, nuclear, hydroelectric, and purchases from other utilities or non-utility power producers. If the resources mix shifts from low cost resources such as hydroelectric generation to higher cost resources such as gas-fired generation, the cost to all customers will increase. Without a new Project license, some of this resource shifting would occur.

- (B) The generation and load projections for 2010 show that SCE hydroelectric generation will represent 6% of the supply of Utility-Retained Generation, which will enable SCE to meet approximately 5% of its load requirements. See Exhibit H(a)(3)(ii) for more detail.
- (C) The Project is located near the communities of Huntington Lake and Big Creek. However, electrical service to these communities relies more on the local power grid in the area than the generation produced by the Project. The service area for power generated by the Project is predominantly the Los Angeles Basin and a portion of the central San Joaquin Valley. SCE would need to purchase replacement power from alternative power sources if a new license is not granted. Replacement power would need to be purchased from the power grid market, which would increase energy costs to SCE customers.

The costs associated with transfer of the license would be the same as the severance value described in Exhibit D(2)(iii).

(3) Need, Cost, and Availability of Alternative Sources of Power

The power produced by the Project cannot be replaced by an alternative source at a lower cost. Following the divestiture of the SCE gas-fired plants, it became necessary for SCE to purchase power during on-peak periods. Changing to an alternative source of power would increase purchased power at a higher cost than continuing operation of the Project.

(i) Average Annual Cost of Power Produced by the Project

The Project has an installed capacity of 174.45 MW and a dependable operating capacity of 181.9 MW. Table H(a)-1 presents the Project's recorded annual generation output for 15 years (1991-2005). The lowest year of generation production in the 15-year period occurred in 1992 at 507,570 MWh and the highest occurred in 1995 at 1,195,652 MWh. The average production for the 15 year period was 824,081 MWh.

The Project Net Investment as of December 31, 2005 was \$37,174,159 and the direct (O&M) expenses for this Project are \$6,750,857, which is an annualized value for the life of the license. Additional Project operating expenses and capital costs are discussed in Section D(4).

Table H(a)-1. Average Project Generation Output Between 1991–2005.

Year	Production in MWH (Transmitted)
1991	580,415
1992	507,570
1993	1,094,090
1994	567,399
1995	1,195,652
1996	1,050,192
1997	898,483
1998	1,094,868
1999	839,673
2000	837,543
2001	570,805
2002	717,201
2003	752,412
2004	708,633
2005	946,278
15-Year Average:	824,081

(ii) The Project Resources Required by SCE to Meet Capacity and Energy Requirements(A) *Energy & Capacity Resources As Separate Components Of Total Resources Required*

SCE currently does not own or operate enough generation to meet all of its future projected load and energy obligations. Table H(a)-2 projects the amount of energy expected from the Utility Retained Generation (URG) in the years 2010 and 2015. This table also gives an estimate of how much of SCE's future energy needs, assuming that the Direct Access load in the SCE service territory will remain constant beyond 2006, will be met by the URG resources. Demand-side management (i.e., conservation and energy efficiency) expectations are built into the table's Load forecast.

Table H(a)-2. Expected Utility Retained Generation (URG) in 2010 and 2015

Generation Source	2010			2015		
	GWH	% Supply	% Load	GWH	% Supply	% Load
Utility-controlled Resources						
Nuclear	15,527	20%	18%	16,902	29%	18%
Hydro	4,775	6%	5%	4,687	8%	5%
Fossil	10,101	13%	11%	10,816	19%	11%
Must-take DWR	19,946	26%	23%	0	0%	0%
Qualifying Facility Contracts	23,581	31%	27%	23,208	40%	24%
Existing Renewable Contracts	2,438	3%	3%	2,434	4%	3%
Total URG*	76,368	100%	87%	58,047	100%	60%

Source: 2005 IEPR Alternative Case, Public Version of Form S-2, filed in CEC by SCE on April 1, 2005.

* URG less interutility contracts (i.e., Hoover, etc.)

(B) *Resource Analysis and System Reserve Margins*

The California Independent System Operator (Cal ISO) is responsible for maintaining statewide system operating reserve margins that meet the WECC required operating reserve margin requirements. The Cal ISO attempts to maintain an operating reserve of about 7%, with 3.5% as spinning reserve and 3.5% as non-spinning reserve. For a breakdown of utility-owned generation, see the above table. In addition to operating reserves, SCE will be required to provide the Cal ISO with documentation related to meeting the state Resource Adequacy or planning reserve margins. This Project can, and will, count towards meeting these planning reserve requirements.

(C) *Effects of Efficiency and Load Management Plans*

SCE has developed comprehensive efficiency and load reduction plans that will encourage electrical customers to decrease their load, especially during peak periods. Reference Exhibit H(a)(11).

SCE is committed to the continued development of cost effective energy efficiency and load management programs that will help the utility provide uninterrupted service to its customers. The 2005 SCE energy efficiency programs achieved over 1,372,000 MWh of net annualized energy savings and a net demand reduction of 265.2 MW.

(iii) Cost and Merits of Project Alternatives

As previously discussed in Exhibit H(a)(2)(i), SCE has very limited options regarding alternative sources of power. At the current time, the only feasible alternative is receiving energy from the wholesale energy market.

(A) *Annual Costs for Alternative Sources of Power*

The cost of replacement power in 2009 is \$56.6 million per year (nominal dollars). See discussion above in Exhibit H(a)(2)(i).

(B) *Basis for Determination of Projected Annual Cost*

The projected annual cost of alternative power is determined by estimating the cost of replacing the power provided by the Project at SCE's forecast of its avoided cost of energy and capacity. As previously noted the number of MWh's needed for replacement was derived from a 15-year annual historical average. This average was then multiplied by the avoided cost of energy and capacity as forecasted by SCE in its 2006 General Rate Case (GRC) filing. Since this forecast is not available past 2008, it is assumed that the

avoided cost will increase at a level consistent with other escalation assumptions as discussed above. See also Exhibit H(a)(3)(i).

(C) *Relative Merits of Each Alternative*

Forward purchases of energy are likely to be characterized by market forces. Their availability is subject to the terms and conditions specified in contracts as well as forces at work in the marketplace. The Project's availability is limited by the amount of water available to be diverted and/or stored upstream of the Project, which is governed by the precipitation available in any given year.

(iv) The Effect on the Direct Providers of Alternative Sources of Energy

Relicensing of the Project would have a negative effect on suppliers of alternative sources of power. It would reduce the amount of purchases made by SCE and increase the total supply of generation in the market, thus likely causing power prices to decrease.

In addition, SCE has long and short-term contracts with both public and private utilities. Generally, when utilities have different peak seasons they can exchange energy and capacity on a seasonal basis for each other's benefit. There would be minor effect to the other utilities from utilizing alternate sources of power as the overall average cost for exchange energy would increase which would create less opportunity to make exchanges.

(4) Effect on Industrial Facilities

The Project does not connect or otherwise provide direct electricity to any of SCE's facilities.

(5) Tribal Need for the Project on a Reservation

Applicant is not an Indian tribe nor is the Project on a Tribal reservation.

(6) Comparison of Impact on Operations and Planning of Transmission System With and Without License Renewal

(i) Transmission and distribution lines and the associated equipment that deliver power from FERC Project No. 120 are part of SCE's transmission and distribution system and are not included in the FERC license for the Project. The Project and other hydroelectric plants in the area dependably deliver a collective total of 1,000 MW of power to serve approximately 1.2 million customers in the San Joaquin Valley and the Los Angeles basin. Removal of the 181 MW of Project generation would result in SCE's inability to adequately serve its customers in the San Joaquin Valley and

Los Angeles basin areas during high load conditions. Insufficient transmission capability south of the San Joaquin Valley, and, in particular, south of the Rector Substation limits SCE's ability to import power into the region. Additional capacity would be necessary to import power to serve the San Joaquin Valley. As a result, significant transmission upgrades, in the form of new 230 kV or 500 kV transmission lines, would be necessary if the Project generation is unavailable. The new transmission lines would need to be connected to the Magunden Substation located 65 miles south of Rector and possibly the Vincent or Pardee Substations located an additional 95 miles south of Magunden, if power were imported from southern California or the southwest. Until such time that the new transmission facilities are constructed, significant involuntary load interruption in violation of established Western Electric Coordinating Council Planning Criteria would be needed during normal and outage conditions when loads are high to ensure remaining transmission facilities do not load beyond the maximum allowable limits.

- (ii) SCE's existing transmission system distributes the Project's power and utilizes the Project's power to serve local substation load. No other distribution or transmission system is currently available to transmit Project power.
- (iii) Customer load demand within the San Joaquin Valley is served by utilizing local area generation resources as well as importing power from the south. The local area generation includes Big Creek Hydro generation resources that collectively add up to over 1,000 MW. Big Creek No. 3 Project generation resources account for approximately 181 MW of this total generation. Power from the south is imported into the San Joaquin Valley through existing 220 kV transmission facilities that originate at the SCE Vincent (Los Angeles County Acton area) and SCE Pardee (Los Angeles County Santa Clarita area) Substations. These transmission lines connect together at the SCE Magunden Substation (Kern County Bakersfield area). From the Magunden Substation, four 220 kV transmission lines run north towards the Big Creek Hydro Facilities connecting three A-Stations (Springville, Rector, and Vestal 220 kV Substation) along the way that serve the local San Joaquin Valley loads. Collectively, these four lines are limited in capacity to approximately 1,000 MW with all facilities in service and 500 to 800 MW (depending on system conditions) under loss of a single transmission line. A single-line diagram of the Big Creek System is shown in Attachment H(a)-1.

(7) Plans for Modifications

SCE has no plans at this time to modify existing Project facilities or operations to increase generation capacity.

(8) Conformance with Comprehensive Plans

The Project facilities and operations, including mitigation measures proposed in Exhibit E, are best adapted to a comprehensive plan for the San Joaquin River based on a balance between environmental protection, water supply, recreation, and the commerce and utilization of a low-cost, non-polluting source of energy. The Project, as proposed in this Application for New License, takes into account all existing and potential uses of the South Fork of the San Joaquin River, including recreation, economically viable hydroelectric generation, energy conservation in the context of the national interests in non-polluting and non-fossil fuel alternatives, public safety, and various aspects of environmental protection, including the prevention of significant detrimental impacts to fish and wildlife resources.

In addition, identification and review of the potentially relevant comprehensive plans indicate that relicensing of the Project will not conflict with the goals or objectives of any such plans. Accordingly, the Project adopts measures to ensure public safety, protect the environment, provide recreation opportunities, and operate for maximum efficiency and reliability, and thus provide the best possible overall mix of benefits.

(9) Financial and Personnel Resources

SCE's source and extent of financing and annual revenues are sufficient to meet the continuing operation and maintenance needs of the Project. For specific financial information, refer to FERC Form No. 1, which is provided to the Commission annually.

SCE has personnel resources necessary to meet license obligations for the Project. A variety of training resources and approaches are used, including classroom training, workshops, textbooks, on-the-job training, and safety training to all personnel. Safety training is conducted through a combination of regularly scheduled monthly meetings, crew meetings, on-the-job training, and special programs as needed. The training covers SCE's Occupational Safety, Health, and Fire Prevention rules and hazardous materials handling, as well as, programs mandated by governmental agencies such as the California Occupational Safety and Health Division, as well as training related to compliance with Commission license articles, and environmental and cultural protection programs.

Job knowledge and skills training programs are available for management, supervisor/administrative, clerical, and craft employees with apprenticeship training programs established for selected job classifications. Individual training needs are evaluated continually and employees are subsequently scheduled into existing programs offered within SCE or into appropriate outside training programs.

Employees are also encouraged to further their education through the educational assistance program, which provides financial assistance for eligible employees who participate in job related courses, correspondence programs, and degree and/or certificate programs sponsored by accredited institutions.

(10) Notification of Expansion to Property Owners

SCE is not proposing to expand the Project to additional lands.

(11) Efficiency Improvement Program

- (i) SCE is actively engaged in energy efficiency, conservation and environmentally beneficial programs. Successful program offerings include customer incentives, information and education, surveys and cooperative efforts with third-party contractors and other utilities. Some of the energy efficiency programs include:

Incentives

SCE's incentive programs include non-residential Value and Energy Stream Mapping (VESM) Advantage Plus Program, Small Nonresidential Hard-to-Reach, Express Efficiency, Standard Performance Contract, Savings by Design and the Upstream HVAC Motors Rebates Program.

SCE's residential incentive programs include Single-family Energy Efficiency Rebates, Multifamily Energy Efficiency Rebates and Appliance Recycling Programs.

Information Programs

SCE's non-residential information programs include Non-residential Energy Surveys, Building Operative Certification, and Pump Test & Hydraulic Services. SCE's Home Energy Efficiency Surveys target residential customers. Other information is disseminated to customers at SCE's Customer Technology and Applications Center, located in Irwindale, California, and SCE's Agricultural Technology Applications Center located in Tulare, California.

Additional information regarding energy efficiency and conservation programs is provided on SCE's website: <http://sce.com>

- (ii) Regulatory compliance and reporting of SCE's energy efficiency programs is tracked through collection, reporting, and verification of information on the programs' performance. The results of the performance of the programs are filed annually with the California Public Utilities Commission pursuant to Protocols and Procedures for the Verification of costs, benefits and shareholder Earnings from Demand-side Management Programs revised June 1999.

(12) Indian Tribes Affected by Project

The Project does not cross any Native American lands; therefore, no lands owned or reserved on behalf of any Native American tribe or tribal organization are affected by the Project.

SCE conducted consultations with the Native American organizations listed below. This contact list was provided by the Sierra National Forest.

Big Sandy Rancheria*
P.O. Box 337
Auberry, CA 93602

Cold Springs Rancheria*
P.O. Box 209
Tollhouse, CA 93667

North Fork Rancheria*
P.O. Box 929
North Fork, CA 93643

Dunlap Band of Mono Indians
P.O. Box 344
Dunlap, CA 93621

Picayune Rancheria*
46575 Road 417
Coarsegold, CA 93614

Table Mountain Rancheria*
23736 Sky Harbor Road
P.O. Box 410
Friant, CA 93626

Mono Nation
P.O. Box 800
North Fork, CA 93643

North Fork Mono Tribe
13396 Tollhouse Road
Clovis, CA 93611

Sierra Nevada Native American Coalition
P.O. Box 125
Dunlap, CA 93621

Bishop Tribal Council
50 Tu Su Lane
Bishop, CA 93514

Sierra Mono Museum
33103 Road 288
North Fork, CA 93643

Native Earth Foundation
34329 Shaver Springs Road
Auberry, CA 93602

Michahai Wuksachi
1174 Rockhaven Ct
Salinas, CA 93906

*Federally recognized tribal organization

ATTACHMENT H(a)-1

Single Line Diagram

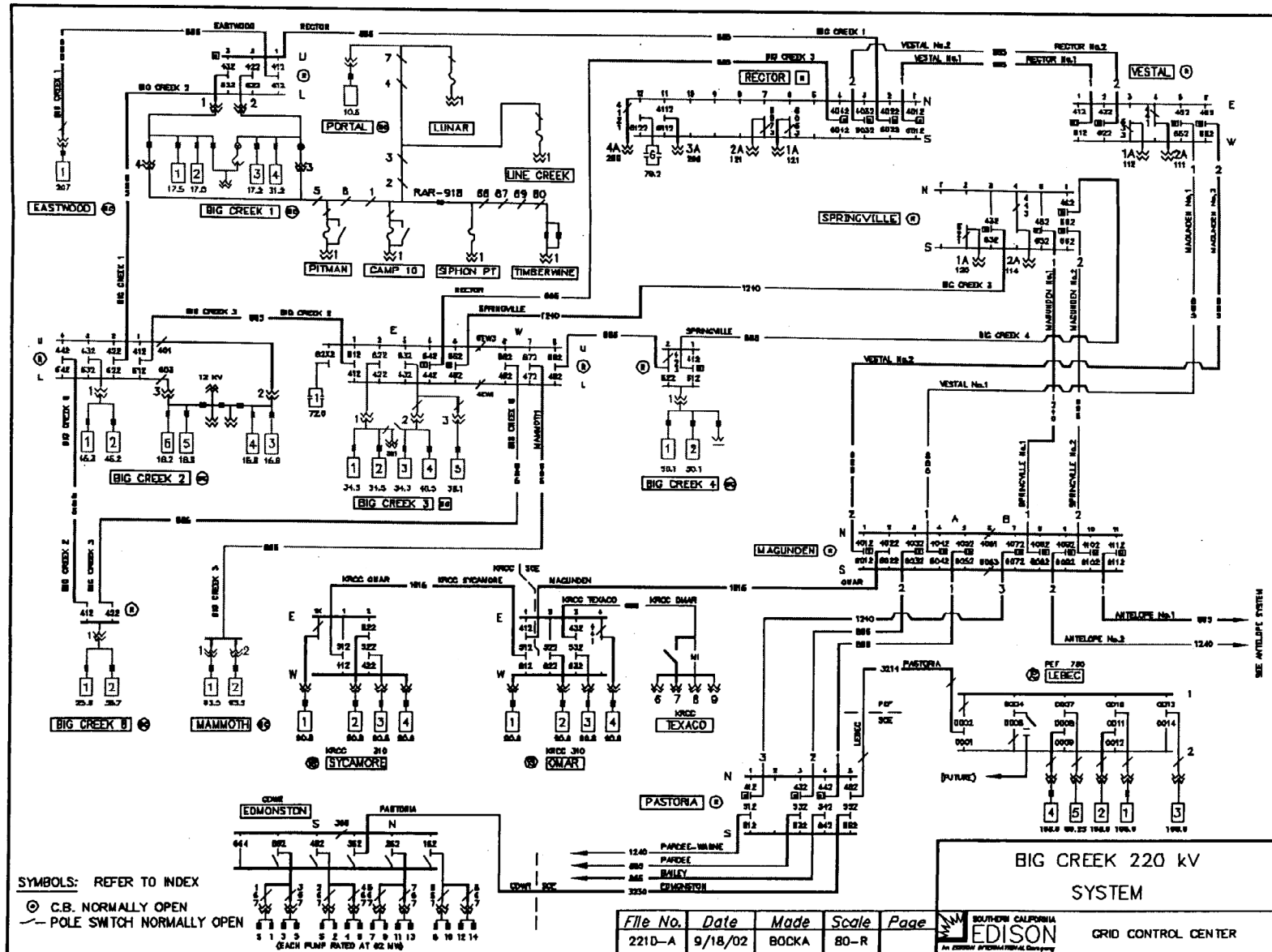

This page left intentionally blank.

SOUTHERN CALIFORNIA EDISON COMPANY

BEFORE THE

FEDERAL ENERGY REGULATORY COMMISSION

APPLICATION FOR NEW LICENSE

BIG CREEK NO. 3
(FERC Project No. 120)

EXHIBIT H(B) GENERAL INFORMATION

CONTAINS PUBLIC INFORMATION

FEBRUARY 2007

Copyright 2007 by Southern California Edison Company. All rights reserved. No part of this publication may be reproduced, stored in a retrieval system, or transmitted, in any form or by any means, electronic, mechanical, photocopying, recording or otherwise, without the prior written permission of the Southern California Edison Company.

Exhibit H(b) General Information

Exhibit H(b) is information to be provided by an applicant who is an existing licensee. An existing licensee that applies for a new license must provide the information as specified in 18 CFR § 16.10(b):

- (1) The information specified in H(a).
- (2) A statement of measures taken or planned by the licensee to ensure safe management, operation, and maintenance of the project, including:
 - (i) A description of existing and planned operation of the project during flood conditions;
 - (ii) A discussion of any warning devices used to ensure downstream public safety;
 - (iii) A discussion of any proposed changes to the operation of the project or downstream development that might affect the existing Emergency Action Plan, as described in subpart C of part 12 of this chapter, on file with the Commission;
 - (iv) A description of existing and planned monitoring devices to detect structural movement or stress, seepage, uplift, equipment failure, or water conduit failure, including a description of the maintenance and monitoring programs used or planned in conjunction with the devices; and
 - (v) A discussion of the project's employee safety and public safety record, including the number of lost-time accidents involving employees and the record of injury or death to the public within the project boundary.
- (3) A description of the current operation of the project, including any constraints that might affect the manner in which the project is operated.
- (4) A discussion of the history of the project and record of programs to upgrade the operation and maintenance of the project.
- (5) A summary of any generation lost at the project over the last five years because of unscheduled outages, including the cause, duration, and corrective action taken.

- (6) A discussion of the licensee's record of compliance with the terms and conditions of the existing license, including a list of all incidents of noncompliance, their disposition, and any documentation relating to each incident.
- (7) A discussion of any actions taken by the existing licensee related to the project which affect the public.
- (8) A summary of the ownership and operating expenses that would be reduced if the project license were transferred from the existing licensee.
- (9) A statement of annual fees paid under Part I of the Federal Power Act for the use of any Federal or Indian lands included within the project boundary.

(1) Information Specified in H(a)

See Exhibit H(a).

(2) Safety Measures

(i) Operation of the Big Creek Powerhouse No. 3 Project

Operation of the Big Creek Powerhouse No. 3 Project is fully automated. The Project is monitored and operated from the Big Creek Powerhouse No. 3 Control Center.

A Station Order Binder is maintained at the Big Creek No. 3 Powerhouse. This document includes individual site specific plans (Station Orders) outlining actions and considerations for high water flow events at each station and/or its associated head and tail works. The Station Orders provide for contingency planning and response to both planned and unplanned project high water flow events. This includes the potential for a single event or, when considered in aggregate, for multiple Powerhouse high water and/or flooding circumstances.

If flooding of the Big Creek No. 3 Powerhouse is imminent, several measures are implemented to prevent water damage to basement equipment and curtailment of powerhouse operation. These measures include: placing cover plates over the drains in the humidifier passageway leading to the draft tube sumps; closing and latching the water-tight door leading to the humidifier passageway; draining miscellaneous oil containments at the powerhouse; checking and cleaning the cooling water filters, as necessary; and, placing the station pump well ejector into operation.

The entire "Big Creek Hydroelectric System," including the Big Creek Powerhouse No. 3 Project, is operated together in a coordinated manner to maximize the hydroelectric power produced from the available water supply and to augment the operation of the federally operated Millerton Reservoir (downstream) as appropriate.

A safety/security assessment was completed for the Big Creek Powerhouse No. 3 Project in 2003 and a critical asset vulnerability assessment was completed in 2004. Both of these assessments were updated in April 2006. Security devices have been installed to protect the Project from acts of terrorism, and the Emergency Action Plan (EAP) includes response measures for emergencies related to both natural causes and acts of terrorism. A copy of the EAP is kept at the Big Creek Powerhouse No. 3 and at the Big Creek Control Center.

(ii) Downstream Public Safety

If a potentially hazardous condition exists or dam failure is imminent, the EAP is implemented and operations personnel and the SCE Energy Control Center are contacted. The situation would then be communicated by Control Center personnel to SCE Hydro Generation Division Management, Pacific Gas & Electric, the U.S. Bureau of Reclamation, the California Office of Emergency Services, the California Highway Patrol, and the Fresno and Madera County Sheriffs' Departments. SCE Hydro Division management would immediately notify FERC and the California Division of Safety of Dams (DSOD). The emergency command center would be immediately established at the Northern Hydro Region Office at Big Creek by SCE personnel to coordinate communications and actions of SCE personnel and each involved agency. At each step of the communications network, an assessment will be made to determine whether the emergency situation requires immediate action and who is responsible for taking such action.

(iii) Changes Affecting the Emergency Action Plan

A copy of the Emergency EAP is kept at Big Creek Powerhouse No. 3 and at the Big Creek Control Center. The EAP is reviewed and updated annually. SCE has no current plans to change the operation of the project or any plans for downstream development that might affect the existing Emergency Action Plan.

(iv) Monitoring Devices

Pressures near the bottom of the penstocks are continuously monitored. If the pressure in the penstock drops below a preset level from the normal operation pressure, an alarm is activated at the Big Creek Control Center at Powerhouse No. 3. The operator would acknowledge the alarm and

review other system parameters such as a drop in generation or unit flow and, after evaluating the system, make a decision on whether to shut the water conveyance system down.

Water levels in the Dam No. 6 impoundment are continuously monitored by level sensors. The sensors are used to determine whether dam failure has occurred. If water levels drop at rates faster than preset levels, an alarm is activated at the Big Creek Control Center at Powerhouse No. 3.

The Big Creek Control Center which is located near Big Creek Powerhouse No. 3 is staffed 24-hours per day and Dam 6 is visited weekly by operations personnel. All Project facilities are inspected by SCE personnel at least once a year. The California Department of Water Resources, DSOD and FERC inspect the Project on an annual basis.

Dam 6 is inspected after significant seismic events. SCE inspects any dam that is within 50 miles of an event of magnitude 5.0 or greater.

No instrumentation has been installed at Dam 6 and, as indicated in the *Eighth Five-Year Safety Inspection* dated April 2002, no significant deficiencies have been noted in the performance of the dam, so instrumentation is not considered necessary. The water level within the Dam 6 impound is monitored by a continuous water stage recorder.

(v) Employee and Public Safety

Nine lost-time industrial accidents have been recorded at this Project in the last ten years. These accidents consist of the following:

- October 29, 1997 – Hernia
- February 12, 1998 – Back Injury
- April 21, 1998 – Back Injury
- September 1, 1999 – Back Injury
- September 20, 1999 – Back Injury
- September 26, 2000 – Broken Elbow/Wrist
- December 11, 2002 – Fractured Hand
- December 16, 2004 – Carpal Tunnel Syndrome
- July 19, 2005 – Back Injury

SCE has no knowledge of any deaths or serious injuries having occurred to the public within the Project boundary. A Public Safety Plan is on file with the FERC that identifies all public safety devices installed at the Project.

(3) Project Operation and Constraints

The first generating unit (Unit 2) of Big Creek Powerhouse No. 3 commenced operation on September 30, 1923. Generating Units Nos. 1 and 3 were placed into operation on October 3, 1923 and October 5, 1923, respectively. Generating Unit 4 began operation on April 28, 1948 and Unit 5 began operation on February 24, 1980. The individual installed ratings for each turbine are as follows:

- The Unit 1 turbine is rated at 41,300 HP at a design head of 740 feet and operates at 514 RPM;
- The Unit 2 turbine is rated at 41,300 HP at a design head of 740 feet and operates at 514 RPM;
- The Unit 3 turbine is rated at 41,300 HP at a design head of 740 feet and operates at 514 RPM;
- The Unit 4 turbine is rated at 49,500 HP at a design head of 750 feet and operates at 450 RPM; and
- The Unit 5 turbine is rated at 57,700 HP at a design head of 802 feet and operates at 450 RPM.

The Units 1, 2, and 3 generators are Y-connected, vertical shaft, partially enclosed Westinghouse units. These generators have installed ratings of 34,000 kVA, unity power factor, three-phase, 13.8 kV, 60 Hz. The Unit 4 generator consists of a Y-connected, vertical shaft, Westinghouse unit that has an installed rating of 40,000 kVA, 36,000 kW, three-phase, 12.5 kV, 60 Hz. The Unit 5 generator consists of a Y-connected, vertical shaft, totally enclosed Allis-Chalmers unit with an installed rating of 40,500 kVA, 36,450 kW, three-phase, 13.8 kV, 60 Hz.

Operation of the Big Creek Powerhouse No. 3 Project is fully automated. The Project is monitored and operated from the Big Creek Powerhouse No. 3 Control Center.

Flow above Dam 6 is normally controlled by discharge from the Mammoth Pool Powerhouse (FERC Project No. 2085) and Big Creek Powerhouse 8 (FERC Project No. 67) and is supplemented during floods by spill at Mammoth Pool Dam and flow in Big Creek. The reservoir at Dam 6 serves as an afterbay for Big Creek Powerhouse No. 8 and a forebay for Big Creek Powerhouse No. 3 with only a few feet of drawdown utilized. There is no specific minimum pool elevation for the reservoir. Additional stream flows below Dam 6 are contributed by Stevenson Creek and Jose Creek, which join the San Joaquin River in the bypass reach upstream of Big Creek No. 3 powerhouse.

Project operation and constraints are discussed in Exhibit B, Section (1).

(4) Project History and Upgrades

The Project was constructed between 1921 and 1923. The Project was designed and constructed by Southern California Edison Company. Construction of Tunnel No. 3 commenced in the fall of 1921 and was completed on August 26, 1923, construction of Powerhouse No. 3 began on June 5, 1922 and was completed in 1923, and construction of Dam 6 began in fall 1922 and was completed on March 18, 1923.

A discussion of the Project upgrades and modifications since start-up is provided in Exhibit C, Section 1(iii).

(5) Unscheduled Outages

Five years of unscheduled (forced) outages, 2000 to 2005 inclusive, are listed below in Table H (b)-1.

(6) Record of Compliance

There have been no incidents of non-compliance in the past 20 years.

(7) Actions related to the Project which Affect the Public

In the event of an emergency, SCE personnel, through the U.S. Forest Service and the California Highway Patrol, notify the public and the Sheriff's Office. Public safety devices (e.g., fences, locked gates, signs, grab lines, sirens) are installed where necessary to protect the public.

(8) Summary of Ownership and Operating Expenses

If the Project license were transferred, ownership and operating costs that would be reduced include:

Operation and Maintenance Costs (Annualized over License life)	\$ 6,750,857
Depreciation (2005)	1,292,746
Property Taxes (2005)	380,846
A&G Expenses (Calculated from 2005 Net Invest)	<u>\$ 464,677</u>
Total	\$ 8,889,126

(9) Annual Fees

The annual fees for FERC Bill Year 2005, paid under part I of the Federal Power Act, are as follows:

Water for Power	\$ 406,385
Federal Land Rents	<u>50,138</u>
Total	\$ 456,523

Water for Power – charges for the purpose of reimbursing the United States for the costs of the administration of Part I of the Federal Power Act.

Federal Land Rents – annual fees paid for the occupancy of federal lands for reservoirs, dams, flumes, forebays, penstocks, and powerhouses.

Table H(b)-1 Unscheduled Outages - 2000 to 2005.

Unit	Date/Time	Hours Off	Reason	Corrective Action
5	1/24/00 8:58	0.8	Relayed on loss of field.	No cause found.
2	1/27/00 13:33	2.6	Meggar Field.	Repaired meggar field
2	1/31/00 8:22	15.6	Meggar field and repair field leads.	Repaired meggar field and field leads
2	2/1/00 0:01	14.5	Meggar unit and repair and clean field leads.	Repaired meggar field and field leads
5	2/13/00 10:03	0.6	Unit relayed on loss of field.	No cause found.
3	2/16/00 6:13	8.7	Voltage regulator problems.	Checked regulator, no cause found.
5	2/17/00 15:16	139.9	Unit relayed on loss of field.	Repaired problems in solid state excitation circuitry.
3	6/27/00 11:39	10.0	Main guide bearing oil pump failed.	Repaired pump.
2	12/19/00 17:52	3.7	Synchronizer problem.	Repaired synchronizer.
3	12/19/00 17:52	3.1	Synchronizer problem	Repaired synchronizer.
5	1/6/01 14:19	3.3	Control system program problem.	Repaired control system program.
2	1/29/01 8:41	3.1	Loss of neutral ground indication.	Cleaned potential secondary switch blades.
2	3/8/01 12:16	1.6	Broken shear link	Replaced link.
5	4/15/01 15:56	268.9	Broken pressure regulator linkage.	Repaired linkage.
1	4/19/01 14:12	46.9	Penstock expansion joint leaking.	Repacked joint.
1	6/5/01 6:30	4.3	Excessive unit vibration.	Removed rock from runner.
3	7/11/01 6:24	4.6	Repair exciter brush rigging.	Repaired exciter brush rigging.
3	7/12/01 9:15	106.6	Exciter rotor excessive run-out brush rigging failure and broken brushes.	Replaced exciter rotor, repaired rigging, replaced brushes.
5	9/6/01 15:33	1.0	Replace bad slip ring brushes.	Replaced brushes.
5	9/13/01 15:44	5.1	Brake shoes worn out.	Replaced brake shoes.
5	10/17/01 10:03	1.3	Hot slip ring brush.	Replaced brush.
1	2/2/02 6:26	1765.2	Upper and lower guide bearing failure and unit vibration.	Replaced guide bearings
4	2/8/02 6:00	2.5	Thrust bearing oil level low.	Added oil to thrust bearing.
4	3/14/02 18:30	71.3	Main guide bearing lube oil failure	Repaired oil system and bearing.
3	5/17/02 23:35	2.7	Loss of main guide bearing oil pump operation indication	Repaired indication.
5	5/20/02 12:02	2.0	Change short brushes.	Change short brushes
1	8/15/02 11:56	14.6	Main guide bearing AC oil pump motor failed.	Replaced motor.
1	10/4/02 14:11	0.6	Unit tripped from bank diff. relay testing erroneously.	Restarted unit
5	6/9/03 6:27	11.4	Voltage regulator not controlling unit voltage.	Found blown primary fuse on regulating Potential Transformer. Tested circuit and replaced fuse.

Table H(b)-1 Unscheduled Outages - 2000 to 2005 (continued).

Unit	Date/Time	Hours Off	Reason	Corrective Action
3	9/8/03 14:05	0.6	TSO valve sequencer failed	Adjusted sequencer.
2	9/15/03 7:24	8.7	High vibration.	Inspect unit.
2	9/26/03 19:41	908.1	High vibration.	Replaced guide bearings and shaft seal.
5	11/24/03 18:00	21.9	Field CB spring recharger motor failed.	Replaced motor.
1	2/11/04 0:22	6.4	Speeder overtraveled during shut down.	Reset speeder.
5	4/14/04 12:00	2.3	Wicket gate servo motor leaking.	Repacked wicket gate servo motor.
5	4/17/04 17:07	2.8	Unit relayed due to loss of excitation.	Repaired and restarted unit
3	9/15/04 12:08	49.2	Penstock expansion joint leak.	Repacked joint.
5	12/31/04 22:20	1.4	Governor Failed to Reset	Reset Governor
2	01/02/05 23:32	426.2	Wiped Bearing	Repaired Bearing
2	01/25/05 12:55	4.3	Governor Problems	Repaired Governor Pilot Valve
2	04/10/05 6:20	269.6	Hot Bearing	Repaired Bearing
3	05/03/05	17.2	Stator Ground, mouse in Gen Bus	Removed Mouse, Tested Stator
5	06/23/05 16:07	3.1	Broken Speed Switch	Repaired Switch
5	11/30/05 11:04	196.1	Unit relayed Stator Ground prior to synchronism from ESD	No cause found.
1	12/31/05 17:21	2.1	Cooling Water Problems	Cleaned Cooling Water Strainers